

Parts List
for Portable Generator
English

QAS 500 VoD

Engine TAD1641GE

QAS 500 VoD

Engine TAD1641GE

Parts Index.....	5
Warranty and Liability	7
Safety Precautions for Portable Generator	9
Ordering Spare Parts	13
Parts Lists	18



PARTS INDEX

PART	PAGE	PART	PAGE	PART	PAGE
M		S			
MOTOR DRIVE.....	83	SCREEN.....	52, 54, 83		
MOUNTING RAIL.....	52, 54, 56, 83, 92, 93, 94, 95	SELECTOR SWITCH.....	44, 45, 96, 97		
MUFFLER.....	34	SENSOR LEVEL.....	31, 82		
		SEPARATOR.....	46		
O		SERVICE PAK.....	18, 19		
OIL SYSTEM.....	37	SHIELD.....	48		
		SHUNT TRIP.....	52		
P		SHUNT TRIP COIL.....	86, 87, 88, 89, 90, 91, 93, 94, 95		
PAD.....	38	SOCKET.....	86, 87, 88, 89, 90, 91, 92, 93, 94, 95		
PANELLIGHT.....	44, 45, 96	SOCKET OUTLET.....	87, 88, 85, 89, 90, 91, 92, 93, 94, 95		
PARCOOL EG.....	22	SPACER.....	40, 61		
PAROIL.....	20, 21	SPINDLE LOCK.....	44, 45, 96		
PIN.....	38	STAY.....	40		
PIPE CLAMP.....	26, 38	SUPPORT.....	24, 28, 32, 33, 38, 40, 52, 54		
PIPE EXHAUST.....	34	SUPPORT ENGINE.....	46		
PLASTIC BAG.....	40, 79	SWITCH.....	33, 42		
PLASTIC TUBE.....	36	SWITCH SELECTOR.....	52, 54, 83		
PLATE.....	28, 32, 33, 40, 50, 44, 45, 51, 52, 54, 66, 69, 71				
.....	83, 84, 86, 87, 88, 85, 89, 90, 91, 92, 93, 94, 95, 96	T			
PLUG.....	44, 45, 96, 97	TERMINAL.....	50, 44, 45, 52, 54, 56, 83, 85, 96, 97		
PLUGS FOR 3 WAY VALVE.....	23	TERMINAL BOARD.....	50, 85		
POTMETER.....	44, 45, 96	TORUS.....	42		
POWER SUPPLY.....	56	TRANSDUCER CUR.....	54		
PROFILE.....	52, 54, 83	TRANSFORMER.....	52, 54, 83		
PROTECTION.....	40				
PROTECTION CAP.....	38	U			
PROTECTION COVER.....	84, 86, 87, 88	UNDERVOLTAGE TRIP COIL.....	83		
Q		V			
QUICK COUPLING.....	79	VALVE.....	26, 36		
		VIBRATING DAMPER.....	46		
R		VOLTAGE SWITCH.....	44, 45, 96		
RAIL.....	42	VOLTMETER.....	44, 45, 96		
RELAY.....	42				
RESISTOR.....	44, 45, 96, 97	W			
RETAINER.....	64, 65, 66, 67, 68, 69, 70, 71	WARNING LABEL.....	48		
ROOF.....	40, 72, 73, 74, 75	WARNING MARK.....	48		
RUBBER BUFFER.....	32, 33	WINDOW.....	65		
		WIRE HARNESS.....	97		
		WIRING.....	38		

INSTRUCTION MANUAL

Warranty and Liability Limitation

Use only authorized parts.

Any damage or malfunction caused by the use of unauthorized parts is not covered by Warranty or Product Liability.

The manufacturer does not accept any liability for any damage arising for modifications, additions or conversions made without the manufacturer's approval in writing.

Copyright 2004, Atlas Copco Airpower n.v., Antwerp, Belgium.

Any unauthorized use or copying of the contents or any part thereof is prohibited.

This applies in particular to trademarks, model denominations, part numbers and drawings

Garantie- en aansprakelijkheidsbepalingen

Gebruik alleen originele onderdelen.

Beschadigingen of defecten die het gevolg zijn van het gebruik van niet originele onderdelen vallen niet onder garantie of productaansprakelijkheid.

De producent is niet aansprakelijk voor enige schade veroorzaakt door modificatie, toevoeging of ombouw, gemaakt zonder de schriftelijke toestemming van de fabrikant.

Copyright 2004, Atlas Copco Airpower n.v., Antwerpen, België.

Het is niet toegestaan om zonder toestemming de inhoud geheel of gedeeltelijk te kopiëren of anderszins te gebruiken.

Dit betreft vooral trademarks, modelbenamingen, onderdeelnummers en tekeningen.

Limitation de garantie et de responsabilité

Utiliser uniquement les pièces homologuées.

Tout dommage ou mauvais fonctionnement dû à l'utilisation de pièces non homologuées n'est pas couvert par la garantie ou la responsabilité des produits défectueux. Le fabricant décline toute responsabilité en cas de dommage faisant suite à des modifications, des ajouts ou des conversions effectués sans l'accord écrit du fabricant.

Copyright 2004, Atlas Copco Airpower n.v., Antwerp, Belgique.

Toute utilisation ou copie du contenu, ou d'une partie de celui-ci, non autorisée est interdite.

Cette interdiction s'applique en particulier aux marques de commerce, aux dénominations des modèles, aux numéros des pièces et aux schémas.

Garantie- und Haftungseinschränkungen

Nur zugelassene Teile verwenden.

Jede Beschädigung oder Fehlfunktion, die durch die Verwendung von nicht zugelassenen Teilen verursacht wurde, ist nicht durch die Garantie oder Produkthaftung abgedeckt.

Der Hersteller übernimmt keine Haftung für Schäden, die durch Modifizierungen, Ergänzungen oder Funktionsänderungen entstehen, die ohne schriftliche Zustimmung des Herstellers erfolgt sind.

Urheberrecht 2004, Atlas Copco Airpower n.v., Antwerpen, Belgien.

Jede nicht genehmigte Verwendung oder Kopie des Inhaltes oder von Teilen ist untersagt.

Das bezieht sich im Einzelnen auf Warenzeichen, Modellbezeichnungen, Teilenummern und Zeichnungen

Limitación de garantía y responsabilidad

Use sólo piezas autorizadas.

La garantía o responsabilidad del producto no cubre ningún daño o funcionamiento defectuoso provocado por el uso de piezas no autorizadas.

El fabricante no acepta ninguna responsabilidad por los daños provocados por modificaciones, adiciones o conversiones realizadas sin la aprobación por escrito del fabricante.

Derechos de reproducción 2004, Atlas Copco Airpower n.v., Amberes, Bélgica.

Está prohibida toda utilización o reproducción total o parcial no autorizada de estos contenidos,

en especial de las marcas registradas, denominaciones de modelos, números de piezas y planos

Begränsningar av garanti och ansvarsskyldighet

Använd endast godkända delar.

Den skada eller funktionsoduglighet som förorsakats av att ej godkända delar har använts, täcks inte av garantin eller produktansvaret.

Tillverkaren accepterar ingen ansvarsskyldighet för skador som uppstår efter att ändringar, tillägg eller ombyggnader gjorts utan skriftligt tillstånd från tillverkaren.

Copyright 2004, Atlas Copco Airpower n.v., Antwerpen, Belgien.

Ej auktoriserad användning eller kopiering av innehållet, eller delar av det, är förbjuden.

Detta gäller speciellt varumärken, modellbeteckningar, reservdelnummer och ritningar.

Limitazione di Garanzia e di Responsabilità

Usare solo componenti autorizzati.

Qualsiasi danno o malfunzione causati dall'uso di componenti non autorizzati non è coperto dalla Garanzia o dalla Responsabilità sul Prodotto.

Il fabbricante non accetta alcuna responsabilità per danni derivanti da modifiche, aggiunte o trasformazioni effettuate senza l'approvazione scritta del fabbricante.

Copyright 2004, Atlas Copco Airpower n.v., Anversa, Belgio.

Sono vietati ogni uso o copia non autorizzati del contenuto o di qualsiasi parte dello stesso.

Ciò si applica in particolare ai marchi, alle denominazioni dei modelli, ai numeri dei componenti ed ai disegni

Garanti- og ansvarsbegrænsning

Brug kun tilladte reservedele.

Enhver skade eller fejlfunktion, forårsaget af brug af ikke tilladte reservedele, omfattes ikke af garantien eller produktansvaret.

Fabrikanten kan ikke drages til ansvar for nogen skade som følge af ændringer, udvidelser eller ombygninger, der er blevet udført uden fabrikantens skriftlige samtykke.

Copyright 2004, Atlas Copco Airpower n.v., Antwerpen, Belgien.

Enhver uautoriseret brug eller kopiering af indholdet eller dele deraf er forbudt.

Dette gælder især varemærker, modelbenævnelser, delnumre og tegninger.

Εγγύηση και Περιορισμός Ευθύνης

Χρησιμοποιήστε μόνο εγκεκριμένα εξαρτήματα.

Οποιαδήποτε ζημιά ή δυσλειτουργία προκληθεί από τη χρήση μη εγκεκριμένων εξαρτημάτων δεν καλύπτεται από την εγγύηση και την ευθύνη για το προϊόν.

Ο κατασκευαστής δεν αποδέχεται καμία ευθύνη για ζημιές που προκύπτουν από τροποποιήσεις, προσθήκες ή μετατροπές που έγιναν χωρίς τη γραπτή έγκριση του κατασκευαστή.

Copyright 2004, Atlas Copco Airpower n.v., Αμβέρσα, Βέλγιο.

Απαγορεύεται οποιαδήποτε χρήση ή αντιγραφή του περιεχόμενου ή οποιουδήποτε τμήματος του παρόντος χωρίς εξουσιοδότηση.

Αυτό ισχύει συγκεκριμένα για εμπορικά σήματα, ονομασίες μοντέλων, κωδικούς εξαρτημάτων και σχέδια.

Garanti og ansvarsbegrænsning

Brug kun autoriserede deler.

Enhver skade eller funktionsfejl som skyldes brug af uautoriserede deler dekkes ikke af garanti eller produktansvar.

Fabrikanten aksepterer intet ansvar for noen skade som oppstår på grunn av modifikasjoner, tilføyelser eller forandringer som er gjort uten fabrikantens skriftlige tillatelse.

Copyright 2004, Atlas Copco Airpower n.v., Antwerpen, Belgia.

All uautorisert bruk eller kopiering av innholdet eller en del av det er forbudt.

Dette gjelder særlig varemerker, modellbenevnelser, delenumre og tegninger.

Takuun ja vastuuvollisuuden rajoitus

Käytä vain valmistajan hyväksymiä varaosia.

Takuu ja tuotevastuu eivät kata vahinkoja tai toimintahäiriöitä, joiden syynä on muiden kuin hyväksytyjen varaosien käyttö.

Valmistaja ei vastaa vahingoista, jotka aiheutuvat ilman valmistajan kirjallista lupaa tehdyistä muutoksista tai lisäyksistä.

Copyright 2004, Atlas Copco Airpower n.v., Antwerpen, Belgia.

Sisällön osittainenkin käyttö tai kopiointi ilman lupaa on kielletty.

Tämä koskee erityisesti tavaramerkkejä, mallien nimiä, osanumeroita ja piirustuksia.

Garantijas un atbildības ierobežojumi

Izmantot tikai ieteiktās rezerves daļas.

Īdi garantija nesedz bojājumus vai disfunkciju, kuri ir radušies neatītaut rezerves daļu izmantošanas rezultātā.

Raportājs nepieņem pretenzijas par bojājumiem, kas izriet no modifikācijām, papildinājumiem vai pārveidojumiem bez raportāja rakstiskas piekrišanas.

Autortiesības 2004, Atlas Copco Airpower n.v., Antverpene, Beļģija.

Jebkura neatītautā īdi satura izmantošana vai kopšana ir aizliegta. Tas konkrēti attiecas uz tirdzniecības markām, modeļu denominācijām, daļu numuriem un rasējumiem.

QAS 500 VoD

Limites de Garantia e Responsabilidade

Utilize apenas peças autorizadas.

Avarias ou defeitos de funcionamento que sejam causados pelo uso de sobresselentes ou componentes não autorizados não serão cobertos pela Garantia ou pela Responsabilidade de Produto.

O fabricante não aceita qualquer responsabilidade por quaisquer danos resultantes de modificações, adições ou conversões efectuadas sem a aprovação escrita do fabricante.

Copyright 2004, Atlas Copco Airpower n.v., Antuérpia, Bélgica.

Qualquer uso não autorizado ou cópia do conteúdo ou de qualquer parte dele é proibida.

Isto aplica-se em particular a marcas registadas, denominações de modelos, números de peças e desenhos.

有限担保和责任

只允许使用经认可的零件。

因使用未经认可的零件而导致的任何损坏或故障不在本担保或产品责任所保障的范围之内。

未经制造商书面许可，制造商概不负责因擅自对设备进行改动、添加附件或改造而导致的设备损坏。

版权 2004，比利时安特卫普 Atlas Copco Airpower n.v.。

未经许可，禁止使用或复制本手册中所含的全部或任何一部分内容。

本公告特别适用于本手册所含的商标、型号名称、零件代号和图纸。

A garancia és felelősség korlátozása

Csak jóváhagyott alkatrészeket használjon!

A nem jóváhagyott alkatrészek használatából adódó sérülésekre és üzembazarra nem terjed ki a garancia és a termékfelelősség.

A gyártó semminemű felelősséget nem vállal a gyártó írásos jóváhagyása nélkül végzett bármilyen módosításokból, kiegészítésekből vagy átalakításokból adódó sérülésekért.

Copyright 2004, Atlas Copco Airpower n.v., Antwerp, Belgium.

A kézikönyv tartalma vagy annak egy részének engedély nélküli felhasználása vagy másolása tilos. Ez vonatkozik különösen a védjegyekre, a típusjelölésekre, cikkszámokra és rajzokra.

Záruka a obmedzenia zodpovednosti výrobcu

Používajte len schválené súčiastky.

Akákóľvek škoda alebo porucha spôsobená použitím neschválených súčiastok nie je zahrnutá v záruke ani zodpovednosti výrobcu za škodu.

Výrobca nepripúšťa žiadnu zodpovednosť za akékóľvek škody vzniknuté úpravou, pridaním alebo prerobením, ktoré boli vykonané bez predchádzajúceho písomného súhlasu výrobcu.

Autorské práva 2004, Atlas Copco Airpower n.v., Antverpy, Belgicko.

Akékóľvek neoprávnené použitie alebo kopírovanie obsahu, alebo jeho časti je zakázané.

Toto sa vzťahuje najmä na obchodné značky, modelové označenia, čísla súčiastok a nákresy.

Garantii ja piiratud vastutus

Kasutage ainult valmistaja poolt aktsepteeritud varuosi.

Mis tahes vigastus või rike, mille on põhjustanud valmistaja poolt aktsepteerimata varuosa kasutamine, ei kuulu toote garantii või tootja vastutuse alla.

Valmistaja ei aktsepteeri ühtegi riket, mis on tekkinud toote modifitseerimisest, lisandustest või ümberehitamisest, mida valmistaja ei ole kirjilikult heaks kiitnud.

Copyright 2004, Atlas Copco Airpower n.v., Antwerp, Belgium.

Käesoleva juhendi mistahes loata kasutamine või kopeerimine on keelatud.

See kehtib nii kaubamärkide, mudeli nimetuste, varuosade numbrite kui ka jooniste kohta.

Ограничение гарантии и ответственности

Используйте компоненты только авторизованных поставщиков.

Не распространяется гарантия и ответственность за продукцию при любых повреждениях или неисправностях в результате использования неавторизованных компонентов.

Производитель не несет никакой ответственности за любые повреждения, возникшие в результате модификации, дополнения или изменения, выполненные без письменного утверждения производителя.

Copyright 2004, Atlas Copco Airpower n.v., Антверпен, Бельгия.

Запрещается любое несанкционированное использование или копирование содержания этих материалов или их части. В особенности это относится к торговым маркам, обозначениям моделей, номерам деталей и чертежам.

Gwarancja i ograniczenie odpowiedzialności

Stosować jedynie oryginalne części zamienne.

Jakiekolwiek uszkodzenia lub niesprawności spowodowane stosowaniem niezaprobowanych części zamiennych nie są objęte gwarancją lub odpowiedzialnością za produkt.

Producent nie będzie ponosił żadnej odpowiedzialności za jakiegokolwiek szkody spowodowane modyfikacjami, dodatkami lub zmianami wykonanymi bez pisemnej zgody producenta.

Copyright 2004, Atlas Copco Airpower n.v., Antwerpia, Belgia.

Wszelkie stosowanie lub kopiowanie zawartości lub jakiegokolwiek części publikacji bez zezwolenia jest zabronione.

Dotyczy to szczególnie znaków handlowych, oznaczeń modeli, numerów części oraz rysunków.

Omezení záruky a odpovědnosti

Používejte pouze takové součásti, které jsou schválené výrobcem zařízení. Jakékoli poškození nebo závady způsobené použitím součástí, které nebyly schválené výrobcem zařízení, nejsou kryty zárukou, nebo odpovědností za výrobek.

Výrobce nepřijímá žádnou odpovědnost za jakékoli škody, způsobené modifikacemi, doplňky nebo přestavbami zařízení provedenými bez předchozího písemného svolení.

Copyright 2004, Atlas Copco Airpower n.v., Antverpy, Belgie.

Jakékoli neoprávnené použitie alebo kopírovanie obsahu tohoto dokumentu alebo ktorékóľv jeho časti je zakázané. Toto platí obzvlášť pre obchodní známky, označení modelů, čísla součástí a výkresovou dokumentaci.

Garancijski pogoji in omejitve

Uporabljajte samo odobrene dele.

Garancija proizvajalca ni veljavna pri poškodbah ali motnjah v delovanju, ki so posledica uporabe neodobrenih delov.

Proizvajalec ne prevzema nikakršne odgovornosti za poškodbe, ki so nastale zaradi sprememb, dodatkov ali prilagoditev na izdelku, ki so bile izvedene brez pisne odobritve proizvajalca.

Copyright 2004, Atlas Copco Airpower n.v., Antwerp, Belgium.

Brez pisnega dovoljenja ni dovoljeno uporabljati ali razmnoževati nobenega dela dokumenta.

To velja še posebno za blagovne znamke, označbe modelov, številke izdelkov in risbe.

Garantijos ir atsakomybės galiojimas

Naudokite tik originalias dalis.

Garantija nebus taikoma tuo atveju, jeigu žala ar sutrikimas atsiranda naudojant neoriginalias dalis.

Gamintojas neprisiima jokios atsakomybės dėl žalos, susijusios su modifikacija, papildymu ar perdirbimu, atliktu be raštiško gamintojo sutikimo.

Autorstës teisë 2004, "Atlas Copco Airpower n.v.", Antverpenas, Belgija.

Neteisëtas viso teksto ar kurios nors jo dalies panaudojimas ar kopijavimas yra draudþiamas.

Visø pirma õi sãlyga taikoma prekiniams þenkams, modeliø pavadinimams, daliø numeriams ir brëþiniams.

SAFETY PRECAUTIONS FOR PORTABLE GENERATORS

To be read attentively and acted accordingly before towing, lifting, operating, performing maintenance or repairing the generator

0.1 INTRODUCTION

The policy of Atlas Copco is to provide the users of their equipment with safe, reliable and efficient products. Factors taken into account are among others:

- the intended and predictable future use of the products, and the environments in which they are expected to operate,
- applicable rules, codes and regulations,
- the expected useful product life, assuming proper service and maintenance,
- providing the manual with up-to-date information.

Before handling any product, take time to read the relevant instruction manual. Besides giving detailed operating instructions, it also gives specific information about safety, preventive maintenance, etc. Keep the manual always at the unit location, easy accessible to the operating personnel.

See also the safety precautions of the engine and possible other equipment, which are separately sent along or are mentioned on the equipment or parts of the unit.

These safety precautions are general and some statements will therefore not always apply to a particular unit.

Only people that have the right skills should be allowed to operate, adjust, perform maintenance or repair on Atlas Copco equipment. It is the responsibility of management to appoint operators with the appropriate training and skill for each category of job.

Skill level 1: Operator

An operator is trained in all aspects of operating the unit with the push-buttons, and is trained to know the safety aspects.

Skill level 2: Mechanical technician

A mechanical technician is trained to operate the unit the same as the operator. In addition, the mechanical technician is also trained to perform maintenance and repair, as described in the instruction manual, and is allowed to change settings of the control and safety system. A mechanical technician does not work on live electrical components.

Skill level 3: Electrical technician

An electrical technician is trained and has the same qualifications as both the operator and the mechanical technician. In addition, the electrical technician may carry out electrical repairs within the various enclosures of the unit. This includes work on live electrical components.

Skill level 4: Specialist from the manufacturer

This is a skilled specialist sent by the manufacturer or its agent to perform complex repairs or modifications to the equipment.

In general it is recommended that not more than two people operate the unit, more operators could lead to unsafe operating conditions. Take necessary steps to keep unauthorized persons away from the unit and

eliminate all possible sources of danger at the unit.

When handling, operating, overhauling and/or performing maintenance or repair on Atlas Copco equipment, the mechanics are expected to use safe engineering practices and to observe all relevant local safety requirements and ordinances. The following list is a reminder of special safety directives and precautions mainly applicable to Atlas Copco equipment.

Neglecting the safety precautions may endanger people as well as environment and machinery:

- endanger people due to electrical, mechanical or chemical influences,
- endanger the environment due to leakage of oil, solvents or other substances,
- endanger the machinery due to function failures.

All responsibility for any damage or injury resulting from neglecting these precautions or by non-observance of ordinary caution and due care required in handling, operating, maintenance or repair, also if not expressly mentioned in this instruction manual, is disclaimed by Atlas Copco.

The manufacturer does not accept any liability for any damage arising from the use of non-original parts and for modifications, additions or conversions made without the manufacturer's approval in writing.

If any statement in this manual does not comply with local legislation, the stricter of the two shall be applied.

Statements in these safety precautions should not be interpreted as suggestions, recommendations or inducements that it should be used in violation of any applicable laws or regulations.

0.2 GENERAL SAFETY PRECAUTIONS

- 1 The owner is responsible for maintaining the unit in a safe operating condition. Unit parts and accessories must be replaced if missing or unsuitable for safe operation.
- 2 The supervisor, or the responsible person, shall at all times make sure that all instructions regarding machinery and equipment operation and maintenance are strictly followed and that the machines with all accessories and safety devices, as well as the consuming devices, are in good repair, free of abnormal wear or abuse, and are not tampered with.
- 3 Whenever there is an indication or any suspicion that an internal part of a machine is overheated, the machine shall be stopped but no inspection covers shall be opened before sufficient cooling time has elapsed; this to avoid the risk of spontaneous ignition of oil vapour when air is admitted.
- 4 Normal ratings (pressures, temperatures, speeds, etc.) shall be durably marked.
- 5 Operate the unit only for the intended purpose and within its rated

limits (pressure, temperature, speeds, etc.).

- 6 The machinery and equipment shall be kept clean, i.e. as free as possible from oil, dust or other deposits.
- 7 To prevent an increase in working temperature, inspect and clean heat transfer surfaces (cooler fins, intercoolers, water jackets, etc.) regularly. See the maintenance schedule.
- 8 All regulating and safety devices shall be maintained with due care to ensure that they function properly. They may not be put out of action.
- 9 Pressure and temperature gauges shall be checked regularly with regard to their accuracy. They shall be replaced whenever outside acceptable tolerances.
- 10 Safety devices shall be tested as described in the maintenance schedule of the instruction manual to determine that they are in good operating condition.
- 11 Mind the markings and information labels on the unit.
- 12 In the event the safety labels are damaged or destroyed, they must be replaced to ensure operator safety.
- 13 Keep the work area neat. Lack of order will increase the risk of accidents.
- 14 When working on the unit, wear safety clothing. Depending on the kind of activities these are: safety glasses, ear protection, safety helmet (including visor), safety gloves, protective clothing, safety shoes. Do not wear the hair long and loose (protect long hair with a hairnet), or wear loose clothing or jewelry.
- 15 Take precautions against fire. Handle fuel, oil and anti-freeze with care because they are inflammable substances. Do not smoke or approach with naked flame when handling such substances. Keep a fire-extinguisher in the vicinity.
- 16a **Portable generators (with earthing pin):**
Earth the generator as well as the load properly.
- 16b **Portable generators IT:**
Note: This generator is built to supply a sheer alternating current IT network.
Earth the load properly.

0.3 SAFETY DURING TRANSPORT AND INSTALLATION

To lift a unit, all loose or pivoting parts, e.g. doors and towbar, shall first be securely fastened.

Do not attach cables, chains or ropes directly to the lifting eye; apply a crane hook or lifting shackle meeting local safety regulations. Never allow sharp bends in lifting cables, chains or ropes.

Helicopter lifting is not allowed.

It is strictly forbidden to dwell or stay in the risk zone under a lifted load. Never lift the unit over people or residential areas. Lifting acceleration and retardation shall be kept within safe limits.

- 1 Before towing the unit:
 - check the towbar, the brake system and the towing eye. Also check the coupling of the towing vehicle,
 - check the towing and brake capability of the towing vehicle,
 - check that the towbar, jockey wheel or stand leg is safely locked in the raised position,
 - ascertain that the towing eye can swivel freely on the hook,
 - check that the wheels are secure and that the tyres are in good condition and inflated correctly,
 - connect the signalisation cable, check all lights and connect the pneumatic brake couplers,
 - attach the safety break-away cable or safety chain to the towing vehicle,
 - remove wheel chocks, if applied, and disengage the parking brake.
- 2 To tow a unit use a towing vehicle of ample capacity. Refer to the documentation of the towing vehicle.
- 3 If the unit is to be backed up by the towing vehicle, disengage the overrun brake mechanism (if it is not an automatic mechanism).
- 4 Never exceed the maximum towing speed of the unit (mind the local regulations).
- 5 Place the unit on level ground and apply the parking brake before disconnecting the unit from the towing vehicle. Unclip the safety break-away cable or safety chain. If the unit has no parking brake or jockey wheel, immobilize the unit by placing chocks in front of and/or behind the wheels. When the towbar can be positioned vertically, the locking device must be applied and kept in good order.
- 6 To lift heavy parts, a hoist of ample capacity, tested and approved according to local safety regulations, shall be used.
- 7 Lifting hooks, eyes, shackles, etc., shall never be bent and shall only have stress in line with their design load axis. The capacity of a lifting device diminishes when the lifting force is applied at an angle to its load axis.
- 8 For maximum safety and efficiency of the lifting apparatus all lifting members shall be applied as near to perpendicular as possible. If

required, a lifting beam shall be applied between hoist and load.

- 9 Never leave a load hanging on a hoist.
- 10 A hoist has to be installed in such a way that the object will be lifted perpendicular. If that is not possible, the necessary precautions must be taken to prevent load-swinging, e.g. by using two hoists, each at approximately the same angle not exceeding 30° from the vertical.
- 11 Locate the unit away from walls. Take all precautions to ensure that hot air exhausted from the engine and driven machine cooling systems cannot be recirculated. If such hot air is taken in by the engine or driven machine cooling fan, this may cause overheating of the unit; if taken in for combustion, the engine power will be reduced.
- 12 Generators shall be stalled on an even, solid floor, in a clean location with sufficient ventilation. If the floor is not level or can vary in inclination, consult Atlas Copco.
- 13 The electrical connections shall correspond to local codes. The machines shall be earthed and protected against short circuits by fuses or circuit breakers.
- 14 Never connect the generator outlets to an installation which is also connected to a public mains.
- 15 Before connecting a load, switch off the corresponding circuit breaker, and check whether frequency, voltage, current and power factor comply with the ratings of the generator.

0.4 SAFETY DURING USE AND OPERATION

- 1 When the unit has to operate in a fire-hazardous environment, each engine exhaust has to be provided with a spark arrestor to trap incendiary sparks.
- 2 The exhaust contains carbon monoxide which is a lethal gas. When the unit is used in a confined space, conduct the engine exhaust to the outside atmosphere by a pipe of sufficient diameter; do this in such a way that no extra back pressure is created for the engine. If necessary, install an extractor. Observe any existing local regulations. Make sure that the unit has sufficient air intake for operation. If necessary, install extra air intake ducts.
- 3 When operating in a dust-laden atmosphere, place the unit so that dust is not carried towards it by the wind. Operation in clean surroundings considerably extends the intervals for cleaning the air intake filters and the cores of the coolers.
- 4 Never remove a filler cap of the cooling water system of a hot engine. Wait until the engine has sufficiently cooled down.
- 5 Never refill fuel while the unit is running, unless otherwise stated in the Atlas Copco Instruction Book (AIB). Keep fuel away from hot parts such as air outlet pipes or the engine exhaust. Do not smoke

when fuelling. When fuelling from an automatic pump, an earthing cable should be connected to the unit to discharge static electricity. Never spill nor leave oil, fuel, coolant or cleansing agent in or around the unit.

- 6 All doors shall be shut during operation so as not to disturb the cooling air flow inside the bodywork and/or render the silencing less effective. A door should be kept open for a short period only e.g. for inspection or adjustment.
- 7 Periodically carry out maintenance works according to the maintenance schedule.
- 8 Stationary housing guards are provided on all rotating or reciprocating parts not otherwise protected and which may be hazardous to personnel. Machinery shall never be put into operation, when such guards have been removed, before the guards are securely reinstalled.
- 9 Noise, even at reasonable levels, can cause irritation and disturbance which, over a long period of time, may cause severe injuries to the nervous system of human beings. When the sound pressure level, at any point where personnel normally has to attend, is:
 - below 70 dB(A): no action needs to be taken,
 - above 70 dB(A): noise-protective devices should be provided for people continuously being present in the room,
 - below 85 dB(A): no action needs to be taken for occasional visitors staying a limited time only,
 - above 85 dB(A): room to be classified as a noise-hazardous area and an obvious warning shall be placed permanently at each entrance to alert people entering the room, for even relatively short times, about the need to wear ear protectors,
 - above 95 dB(A): the warning(s) at the entrance(s) shall be completed with the recommendation that also occasional visitors shall wear ear protectors,
 - above 105 dB(A): special ear protectors that are adequate for this noise level and the spectral composition of the noise shall be provided and a special warning to that effect shall be placed at each entrance.
- 10 Insulation or safety guards of parts the temperature of which can be in excess of 80 °C (175 °F) and which may be accidentally touched by personnel shall not be removed before the parts have cooled to room temperature.
- 11 Never operate the unit in surroundings where there is a possibility of taking in flammable or toxic fumes.
- 12 If the working process produces fumes, dust or vibration hazards, etc., take the necessary steps to eliminate the risk of personnel injury.

- 13 When using compressed air or inert gas to clean down equipment, do so with caution and use the appropriate protection, at least safety glasses, for the operator as well as for any bystander. Do not apply compressed air or inert gas to your skin or direct an air or gas stream at people. Never use it to clean dirt from your clothes.
- 14 When washing parts in or with a cleaning solvent, provide the required ventilation and use appropriate protection such as a breathing filter, safety glasses, rubber apron and gloves, etc.
- 15 Safety shoes should be compulsory in any workshop and if there is a risk, however small, of falling objects, wearing of a safety helmet should be included.
- 16 If there is a risk of inhaling hazardous gases, fumes or dust, the respiratory organs must be protected and depending on the nature of the hazard, so must the eyes and skin.
- 17 Remember that where there is visible dust, the finer, invisible particles will almost certainly be present too; but the fact that no dust can be seen is not a reliable indication that dangerous, invisible dust is not present in the air.
- 18 Never operate the generator in excess of its limits as indicated in the technical specifications and avoid long no-load sequences.
- 19 Never operate the generator in a humid atmosphere. Excessive moisture causes worsening of the generator insulation.
- 20 Do not open electrical cabinets, cubicles or other equipment while voltage is supplied. If such cannot be avoided, e.g. for measurements, tests or adjustments, have the action carried out by a qualified electrician only, with appropriate tools, and ascertain that the required bodily protection against electrical hazards is applied.
- 21 Never touch the power terminals during operation of the machine.
- 22 Whenever an abnormal condition arises, e.g. excessive vibration, noise, odour, etc., switch the circuit breakers to OFF and stop the engine. Correct the faulty condition before restarting.
- 23 Check the electric cables regularly. Damaged cables and insufficient lightening of connections may cause electric shocks. Whenever damaged wires or dangerous conditions are observed, switch the circuit breakers to OFF and stop the engine. Replace the damaged wires or correct the dangerous condition before restarting. Make sure that all electric connections are securely tightened.
- 24 Avoid overloading the generator. The generator is provided with circuit breakers for overload protection. When a breaker has tripped, reduce the concerned load before restarting.
- 25 If the generator is used as stand-by for the mains supply, it must not be operated without control system which automatically disconnects the generator from the mains when the mains supply is restored.
- 26 Never remove the cover of the output terminals during operation. Before connecting or disconnecting wires, switch off the load and the circuit breakers, stop the machine and make sure that the machine

cannot be started inadvertently or there is any residual voltage on the power circuit.

- 27 Running the generator at low load for long periods will reduce the lifetime of the engine.

0.5 SAFETY DURING MAINTENANCE AND REPAIR

Maintenance, overhaul and repair work shall only be carried out by adequately trained personnel; if required, under supervision of someone qualified for the job.

- 1 Use only the correct tools for maintenance and repair work, and only tools which are in good condition.
- 2 Parts shall only be replaced by genuine Atlas Copco replacement parts.
- 3 All maintenance work, other than routine attention, shall only be undertaken when the unit is stopped. Steps shall be taken to prevent inadvertent starting. In addition, a warning sign bearing a legend such as "work in progress; do not start" shall be attached to the starting equipment.
On engine-driven units the battery shall be disconnected and removed or the terminals covered by insulating caps.
On electrically driven units the main switch shall be locked in open position and the fuses shall be taken out. A warning sign bearing a legend such as "work in progress; do not supply voltage" shall be attached to the fuse box or main switch.
- 4 Prior to stripping an engine or other machine or undertaking major overhaul on it, prevent all movable parts from rolling over or moving.
- 5 Make sure that no tools, loose parts or rags are left in or on the machine. Never leave rags or loose clothing near the engine air intake.
- 6 Never use flammable solvents for cleaning (fire-risk).
- 7 Take safety precautions against toxic vapours of cleaning liquids.
- 8 Never use machine parts as a climbing aid.
- 9 Observe scrupulous cleanliness during maintenance and repair. Keep away dirt, cover the parts and exposed openings with a clean cloth, paper or tape.
- 10 Never weld on or perform any operation involving heat near the fuel or oil systems. Fuel and oil tanks must be completely purged, e.g. by steam-cleaning, before carrying out such operations. Never weld on, or in any way modify, pressure vessels. Disconnect the alternator cables during arc welding on the unit.
- 11 Support the towbar and the axle(s) securely if working underneath the unit or when removing a wheel. Do not rely on jacks.
- 12 Do not remove any of, or tamper with, the sound-damping material. Keep the material free of dirt and liquids such as fuel, oil and cleansing

agents. If any sound-damping material is damaged, replace it to prevent the sound pressure level from increasing.

- 13 Use only lubricating oils and greases recommended or approved by Atlas Copco or the machine manufacturer. Ascertain that the selected lubricants comply with all applicable safety regulations, especially with regard to explosion or fire-risk and the possibility of decomposition or generation of hazardous gases. Never mix synthetic with mineral oil.
- 14 Protect the engine, alternator, air intake filter, electrical and regulating components, etc., to prevent moisture ingress, e.g. when steam-cleaning.
- 15 When performing any operation involving heat, flames or sparks on a machine, the surrounding components shall first be screened with non-flammable material.
- 16 Never use a light source with open flame for inspecting the interior of a machine.
- 17 When repair has been completed, the machine shall be barred over at least one revolution for reciprocating machines, several revolutions for rotary ones to ensure that there is no mechanical interference within the machine or driver. Check the direction of rotation of electric motors when starting up the machine initially and after any alteration to the electrical connection(s) or switch gear, to check that the oil pump and the fan function properly.
- 18 Maintenance and repair work should be recorded in an operator's logbook for all machinery. Frequency and nature of repairs can reveal unsafe conditions.
- 19 When hot parts have to be handled, e.g. shrink fitting, special heat-resistant gloves shall be used and, if required, other body protection shall be applied.
- 20 When using cartridge type breathing filter equipment, ascertain that the correct type of cartridge is used and that its useful service life is not surpassed.
- 21 Make sure that oil, solvents and other substances likely to pollute the environment are properly disposed of.
- 22 Before clearing the generator for use after maintenance or overhaul, submit it to a testrun, check that the AC power performance is correct and that the control and shutdown devices function correctly.

0.6 TOOL APPLICATIONS SAFETY

Apply the proper tool for each job. With the knowledge of correct tool use and knowing the limitations of tools, along with some common sense, many accidents can be prevented.

Special service tools are available for specific jobs and should be used when recommended. The use of these tools will save time and prevent damage to parts.

0.7 SPECIFIC SAFETY PRECAUTIONS

Batteries

When servicing batteries, always wear protecting clothing and glasses.

- 1 The electrolyte in batteries is a sulphuric acid solution which is fatal if it hits your eyes, and which can cause burns if it contacts your skin. Therefore, be careful when handling batteries, e.g. when checking the charge condition.
- 2 Install a sign prohibiting fire, open flame and smoking at the post where batteries are being charged.
- 3 When batteries are being charged, an explosive gas mixture forms in the cells and might escape through the vent holes in the plugs. Thus an explosive atmosphere may form around the battery if ventilation is poor, and can remain in and around the battery for several hours after it has been charged. Therefore:
 - never smoke near batteries being, or having recently been, charged,
 - never break live circuits at battery terminals, because a spark usually occurs.
- 4 When connecting an auxiliary battery (AB) in parallel to the unit battery (CB) with booster cables: connect the + pole of AB to the + pole of CB, then connect the - pole of CB to the mass of the unit. Disconnect in the reverse order.

ORDERING SPARE PARTS

ORDERING SPARE PARTS

Always quote the part number, the designation and the quantity of the parts required, as well as the type and the serial number of the machine.

EXPLANATION OF THE COLUMNS

REF : REFERENCE CODE

Establishes the connection between a part in the list and a part in the illustration.

"-" means that the part is not shown in the illustration.

PART NUMBER

If no part number is given, the part cannot be obtained as a spare part. Parts marked with a dot are part of the assembly listed right above them.

DESIGNATION

Usually this is the name of the part. For standard parts, in addition to the name, a number of characteristics are given.

QTY : QUANTITY

Indicates the quantity of the part concerned. "AR" stands for "As Required".

BESTELLEN VAN ONDERDELEN

Vermeld steeds het onderdeelnummer, de benaming en het aantal van de gewenste stukken, evenals het type en het serienummer van de machine.

TOELICHTING BIJ DE KOLOMMEN

REF : REFERENTIECODE

Legt het verband tussen een onderdeel uit de lijst en een onderdeel op de tekening. "-" betekent dat het onderdeel niet is getekend.

PART NUMBER : ONDERDEELNUMMER

Indien niet opgegeven is het onderdeel niet als wisselstuk beschikbaar. Onderdelen aangeduid met een stip maken deel uit van het geheel dat boven de betreffende onderdelen staat.

DESIGNATION : BENAMING

Meestal de benaming van het onderdeel. In het geval van standaard onderdelen worden naast de benaming een aantal karakteristieken opgegeven.

QTY : AANTAL

Geeft de hoeveelheid van het betreffende onderdeel weer. De aanduiding "AR" betekent "As Required" (zoals vereist).

COMMANDE DE PIÈCES DETACHEES

Toujours indiquer le numéro de pièce, la désignation, la quantité désirée ainsi que le type et le numéro de série du groupe.

EXPLICATION DES INTITULES DES COLONNES

REF : CODE DE REFERENCE

Réfère à la pièce détachée spécifiée dans la liste et sur l'illustration. "-" implique que la pièce n'est pas indiquée sur l'illustration.

PART NUMBER : NUMERO DE PIECE DETACHEE

Si le numéro n'est pas indiqué, la pièce n'est pas disponible en tant que pièce de rechange.

Les pièces indiquées par un point gras font partie de l'ensemble se trouvant au-dessus des pièces détachées correspondantes.

DESIGNATION

En général, le nom de la pièce. S'il s'agit de pièces standard, outre la désignation, un certain nombre de caractéristiques sont indiquées.

QTY : QUANTITE

Indique la quantité de la pièce détachée. "AR" indique "As required", c'est-à-dire la quantité à déterminer selon le cas.

BESTELLUNG VON ERSATZTEILEN

Stets die Teilenummer, die Bezeichnung, und die Anzahl der gewünschten Teile sowie den Typ und die Seriennummer der Maschine angeben.

INFORMATION ZU DEN SPALTEN

REF : REFERENZCODE

Stellt die Verbindung zwischen einem Teil in der Liste und einem Teil auf der Zeichnung her. "-" bedeutet, daß das Teil nicht in der Zeichnung dargestellt ist.

PART NUMBER : TEILENUMMER

Wenn keine Teilenummer angegeben ist, ist das Teil nicht als Ersatzteil erhältlich.

Mit einem Punkt markierte Teile gehören zu der Einheit, die über den jeweiligen Teilen aufgeführt ist.

DESIGNATION : BEZEICHNUNG

Meistens die Bezeichnung des Teils. Bei Standardteilen werden neben der Bezeichnung einige technische Daten angegeben.

QTY : ANZAHL

Gibt die Anzahl des betreffenden Teils an. Die Angabe "AR" steht für "As Required" (wie erforderlich).

PEDIDO DE PARTES

Siempre comunicar el número de parte, la designación y la cantidad deseada así como el tipo y el número de serie de la máquina.

INFORMACIONES SOBRE LAS COLUMNAS

REF : CODIGO DE REFERENCIA

Establece la conexión entre una parte en la lista y una parte en la ilustración.

"-" quiere decir que la parte no está ilustrada.

PART NUMBER : NUMERO DE PARTE

Si no se da ningún número, quiere decir que la parte no está disponible como parte de recambio.

Partes marcadas con un punto son partes del conjunto indicado más arriba.

DESIGNATION : DESIGNACION

Principalmente el nombre de la parte. En caso de partes estándares, el nombre es seguido por especificaciones.

QTY : CANTIDAD

Indica la cantidad de la parte correspondiente. La indicación "AR" significa "As Required" (como sea requerido).

BESTÄLLNING AV RESERVDLAR

Ange alltid reservdelsnummer, benämning och kvantitet för varje önskad detalj samt maskinens typ och tillverkningsnummer.

TÖRKLARING AV SPALTER

REF : REFERENSNUMMER

Identifierar motsvarande detaljer i listan och illustrationen. "-" betyder att detaljen inte visas i illustrationen.

PART NUMBER : RESERVDLSNUMMER

Om inget reservdelsnummer anges, kan detaljen inte erhållas som reservdel. Detaljer som anges med en punkt ingår i den monteringsatts som listas ovanför dessa.

DESIGNATION : BENÄMNING

Detta är vanligen namnet på detaljen. För standarddetaljer anges förutom namnet ett antal specifikationer.

QTY : KVANTITET

Anger den ifrågakvarande detaljens kvantitet. "AR" (As Required) betyder enligt behov.

ORDERING SPARE PARTS

ORDINAZIONE DI PARTI DI RICAMBIO

Menzionare sempre il numero della parte, la denominazione e il numero de pezzi desiderati, nonché il tipo e il numero di serie della macchina.

SPIEGAZIONE DELLE COLONNE

REF : CODICE DI RIFERIMENTO

Stabilisce il nesso tra un pezzo nell'elenco e un pezzo nell'illustrazione. "-" significa che il pezzo non è presente nell'illustrazione.

PART NUMBER : NUMERO DELLA PARTE

Nel caso non sia fornito il numero di parte, il pezzo non può essere ordinato come parte di ricambio.

Il componenti indicati con un puntino fanno parte del gruppo elencato immediatamente sopra di essi.

DESIGNATION : DENOMINAZIONE

Generalmente si tratta della denominazione della parte. Per i pezzi standard oltre alla denominazione sono fornite alcune caratteristiche.

QTY : QUANTITA'

Indica la quantità dei pezzi in questione. "AR" significa "As Required" (Come richiesto).

BESTÄLLNING AV RESERVDLAR

Ange alltid reservdelsnummer, benämning och kvantitet för varje önskad detalj samt maskinens typ och tillverkningsnummer.

TÖRKLARING AV SPALTER

REF : REFERENSNUMMER

Identificerar motsvarande detaljer i listan och illustrationen. "-" betyder att detaljen inte visas i illustrationen.

PART NUMBER : RESERVDLSNUMMER

Om inget reservdelsnummer anges, kan detaljen inte erhållas som reservdel. Detaljer som anges med en punkt ingår i den monteringsatts som listas ovanför dessa.

DESIGNATION : BENÄMNING

Detta är vanligen namnet på detaljen. För standarddetaljer anges förutom namnet ett antal specifikationer.

QTY : KVANTITET

Anger den ifrågavarande detaljens kvantitet. "AR" (As Required) betyder enligt behov.

BESTILLING AV RESERVEDELER

Opggi alltid delenummer, betegnelse og antall på de delene du trenger, samt maskintype og serienummer.

FORKLARING TIL SPALTENE

REF: REFERANSEKODE

Viser hvor en del i listen er vist på illustrasjonen. "-" betyr at delen ikke er vist på illustrasjonen.

DELENUMMER

Hvis delenummer ikke er oppgitt, kan delen ikke bestilles som reservedel. Deler merket med en prikk er del av enheten som er oppgitt like ovenfor de aktuelle delene.

BETEGNELSE

Dette er vanligvis delens navn. Ved standarddeler blir enkelte karakteristika oppgitt i tillegg til navnet.

QTY: ANTALL

Opggir antallet av den aktuelle delen. "EB" betyr "Etter behov".

ΠΑΡΑΓΓΕΛΙΑ ΑΝΤΑΛΛΑΚΤΙΚΩΝ

Πάντοτε σημειώνετε τον κωδικό, τον προσδιορισμό και την ποσότητα των απαιτούμενων ανταλλακτικών, καθώς επίσης τον τύπο και τον αύξοντα κωδικό αριθμό παραγωγής του μηχανήματος.

ΕΞΗΓΗΣΗ ΤΩΝ ΣΤΗΛΩΝ

REF : ΚΩΔΙΚΟΣ ΑΝΑΦΟΡΑΣ

Παρουσιάζει τη σχέση μεταξύ ενός εξαρτήματος στη λίστα και ενός εξαρτήματος στη φωτογραφία. Το "-" σημαίνει ότι το εξάρτημα δεν εμφανίζεται στη φωτογραφία.

PART NUMBER : ΚΩΔΙΚΟΣ ΑΡΙΘΜΟΣ

Αν δεν δίνεται κάποιος κωδικός αριθμός, τότε το εξάρτημα δεν μπορεί να ληφθεί ως ανταλλακτικό.

Τα εξαρτήματα που έχουν μαρκαρισθεί με μία τελεία είναι τμήματα του συλλογήματος που παρουσιάζεται ακριβώς πάνω από αυτά.

DESIGNATION : ΠΡΟΣΔΙΟΡΙΣΜΟΣ

Συνήθως αυτό είναι το όνομα του εξαρτήματος. Για τα βασικά εξαρτήματα, επιπροσθέτα στην ονομασία, δίνεται και ένας αριθμός χαρακτηριστικών.

QTY : ΠΟΣΟΤΗΤΑ

Δηλώνει την ποσότητα του υπόψη εξαρτήματος. "AR" σημαίνει "Ως απαιτείται". Για τα βασικά εξαρτήματα, η ποσότητα δίνεται στη φωτογραφία παρά στη λίστα.

ENCOMENDAS DE PEÇAS

Refira sempre o número da peça, a designação e a quantidade das peças que pretende encomendar, assim como o tipo e o número de série do aparelho.

EXPLICAÇÃO DAS COLUNAS

REF : CÓDIGO DE REFERÊNCIA

Estabeleça a ligação entre a peça na lista e a peça no desenho. "-" significa que a peça não vem no desenho.

PART NUMBER : NÚMERO DA PEÇA

Se não vier referido o número da peça, a peça não pode ser adquirida como peça sobressalente.

As peças marcadas com pontos são peças de um conjunto listado acima dessa peça.

DESIGNATION : DESIGNAÇÃO

Geralmente é o nome da peça. Para peças normalizadas, além do nome da peça, vem também referido um número.

QTY : QUANTIDADE

Indica a quantidade da peça em questão. "AR" (As Required) quer dizer "Como solicitado".

VARAOSIEN TILAAMINEN

Tilauksessa tulee aina mainita osanumero, nimike ja määrä sekä kompresorin tyyppi ja sarjanumero.

SARAKKEIDEN SELITYKSET

REF: VIITE: VIITEKODI

Viitekoodi yhdistää luettelossa mainitun osan kuvassa olevaan. "-" tarkoittaa, että osaa ei ole merkitty kuvaan.

PART NUMBER: OSANUMERO

Ellei osanumeroa ole mainittu, osaa ei ole saatavana varaosana. Pisteellä merkityt osat kuuluvat niiden edellä mainittuun asennelmaan.

DESIGNATION: NIMIKE

Nimikkeenä käytetään tavallisesti osan nimeä. Vakio-osien ollessa kyseessä mainitaan nimen lisäksi osan joitakin ominaisuuksia.

QTY: MÄÄRÄ

Tarkoittaa kyseisten osien lukumäärää. "AR" tarkoittaa "tarpeen mukaan".

ORDERING SPARE PARTS

ZAMAWIANIE CZĘŚCI ZAMIENNYCH

Należy zawsze podawać numery, nazwy i ilości potrzebnych części, a także typ i numer seryjny maszyny.

WYJAŚNIENIE PRZEZNACZENIA KOLUMN

REF: KOD REFERENCYJNY

Kojarzy część na liście z częścią na ilustracji.
Symbol “-” oznacza, że część nie jest przedstawiona na ilustracji.

PART NUMBER (NUMER CZĘŚCI)

Brak numeru oznacza, że dana część nie jest dostępna jako część zamienna. Części oznaczone kropką należą do zespołu wymienionego bezpośrednio nad nimi.

DESIGNATION (NAZWA)

Zwykle jest to nazwa części. W przypadku części standardowych oprócz nazwy podano szereg właściwości.

QTY (IL.): ILOŚĆ

Ilość części danego rodzaju. “AR” (“OP”) oznacza “odpowiednio do potrzeb”.

Заказ запасных частей

Необходимо всегда указывать номер детали, наименование и количество заказываемых запчастей, а также тип и серийный номер устройства.

Расшифровка столбцов

ИЛЛ. : код сноски

Показывает ссылку детали в списке на ее соответствующую иллюстрацию.

"-" означает, что к данной детали нет иллюстраций.

НОМЕР ДЕТАЛИ

Отсутствие номера детали означает, что данная деталь как запчасть не поставляется.

Детали, помеченные точкой, являются частями сборного механизма, который указан над этими деталями.

НАИМЕНОВАНИЕ

Обычно, название детали. К стандартным деталям, кроме названия, могут быть даны некоторые их характеристики.

КОЛ-ВО: Количество

Показывает количество деталей. «По тр.» означает «по требованию».

OBJEDNÁVÁNÍ NÁHRADNÍCH DÍLŮ

V objednávce vždy uveďte číslo dílu, jeho označení a požadované množství. Rovněž tak udejte typ a výrobní číslo zařízení.

VYSVĚTLIVKY K JEDNOTLIVÝM SLOUPCŮM

REF : REFERENČNÍ KÓD

Udává spojitost mezi dílem v seznamu a dílem na obrázku.
“-” znamená, že díl není na obrázku uveden.

ČÍSLO DÍLU

Pokud není číslo dílu uvedeno, nelze tuto součást objednat jako náhradní díl.

Díly označené tečkami jsou součástí konstrukčního celku, který je uveden přímo nad nimi.

OZNAČENÍ

Ve sloupci označení bývá obvykle uveden název dílu. U standardních součástí je vedle názvu uváděna též řada dalších charakteristik.

POĚT : MNOŽSTVÍ

Označuje množství uvedených dílů. Zkratka “PP” znamená “Podle požadavku”.

PÓTALKATRÉSZ-RENDELÉS

Mindig jelezze a szükséges alkatrész számát, megnevezését és mennyiségét, valamint a gép típusát és sorozatszámát.

AZ OSZLOPOK MAGYARÁZATA

REF: REFERENCIAKÓD

Ez teremt kapcsolatot a listán szereplő alkatrész és az ábrán látható alkatrész között.

“-”: azt jelenti, hogy az adott alkatrész nem szerepel az ábrán.

ALKATRÉSZ-SZÁM

Ha nincsen megadva alkatrész-szám, akkor az adott alkatrész nem rendelhető meg pótalkatrészként.

A ponttal jelölt alkatrészek a közvetlenül fölöttük felsorolt szerelvény részét képezik.

MEGNEVEZÉS

Rendszerint ez az alkatrész neve. Az alapfelszereltséghez tartozó alkatrészek esetében a név mellett néhány jellemző adat is szerepel.

QTY: MENNYISÉG

Az adott alkatrész mennyiségét jelzi. “SZ” jelentése “Szükség szerint”

订购备件

请务必提供所需部件的部件号、名称和数量，以及设备型号和序列号。

表格各列说明

REF: 参考代码

确立列表内部件与插图内部件间的联系。
“-”表示插图内未显示此部件。

部件号

如果未给出部件号，则表明无法通过备件方式购买此部件。
标有圆点的部件是其上一行所列配件的一部分。

名称

通常为部件的名称。对于标准件，除了名称外，还会列出它的一些特性。

QTY: 数量

表明可供部件的数量。“AR”代表“根据需要”

OBJEDNÁVANIE NÁHRADNÝCH SÚČIASTOK

Uvádzajte vždy číslo súčiastky, označenie a množstvo požadovaných súčiastok, ako aj typ a výrobné číslo stroja.

VYSVETLENIE STĺPCOV

REF : REFERENČNÝ KÓD

Stanovuje spojitost' medzi súčiastkou v zozname a súčiastkou na obrázku.
“-” znamená, že súčiastka nie je zobrazená na obrázku.

ČÍSLO SÚČIASTKY

Ak nie je uvedené žiadne číslo súčiastky, táto súčiastka nie je k dispozícii ako náhradná.

Súčiastky označené bodkou sú časťou zostavy uvedenej hneď nad nimi.

OZNAČENIE

Obyčajne je to názov súčiastky. U normalizovaných súčiastok sa okrem názvu uvádza aj niekoľko charakteristík

QTY : MNOŽSTVO

Označuje množstvo danej súčiastky. “AR” je skratka pre “Podľa potreby”.

ORDERING SPARE PARTS

NAROČEVANJE NADOMESTNIH DELOV

Zmeraj navedite številko nadomestnega dela, označbo in količino potrebnih delov ter tip in serijsko številko stroja.

RAZLAGA STOLPCEV

REF : REFERENČNA ŠIFRA

Predstavlja povezavo med delom na seznamu in delom na ilustraciji. “-” predstavlja del, ki ni prikazan na ilustraciji.

ŠTEVILKA DELA

Če številka dela ni podana potem je ne morete dobiti kot nadomestni del. Deli označeni s piko so sestavni del montaže, navedene nad njimi.

OZNAČBA

Običajno je to ime nadomestnega dela. Pri standardnih delih je poleg imena podano še število značilnosti.

QTY : KOLIČINA

Označuje količino nadomestnih delov. “AR” pomeni “kot je bilo zahtevano”.

ATSARGINIŲ DALIŲ UĖSAKYMAS

Visuomet nurodykite dalies numerá, pavadinimà ir reikiamà daliŲ kieká, taip pat ir maðinos tipà bei serijiná numerá.

STULPELIŲ PAAIKINIMAI

NRD.: NUORODOS KODAS

Susieja sàraðe nurodytà dalá su jos atvaizdu iliustracijoje. “-” reiðkia, jog dalis iliustracijoje nepavaizduota.

DALIES NUMERIS

Jei numerio nenurodyta, detalës negalima ásigyti kaip atsarginës dalies. Taðku paþymëtos dalys yra priedð jas sàraðe nurodyto mazgo sudëtinë dalis.

PAVADINIMAS

Paprastai tai dalies pavadinimas. Standartinëms dalims kartu su pavadinimu nurodomos ir kelios charakteristikos.

KIEK.: KIEKIS

Nurodo susijusio daliŲ kieká. “AR” reiðkia “As required” (pagal poreiká).

VARUOSADE TELLIMINE

Alati viidake osa numbrile, tãhisele ja vajalikule osade kogusele, samuti masina tũibile ja seerianumbrile.

SELGITUS VEERGUDE KOHTA

REF : VIITENUMBER

Loob seose nimekirjas toodud osa ja illustratsioonil esitatud osa vahel. “-” tãhendab, et illustratsioonil ei ole seda osa kujutatud.

OSA NUMBER

Kui osa numbrit ei ole toodud, pole seda osa võimalik varuosana soetada. Punktiga tãhistatud osad on nende kohal toodud koostu osaks.

TÃHIS

Tavaliselt on see osa nimetus. Standardosadel on lisaks nimetusele toodud ka tunnusnumber.

QTY : KOGUS

Osutab vastava osa kogusele. “AR” tãhendab vajadusel (“As Required”).

REZERVES DAĪU PASŪTĪANA

Vienmçr miniet daĪas numuru, apzĪmçjumu un nepiecieðamo detaĪu daudzumu, kã arĪ maðinas tipu un sçrijas numuru.

AIĻU IZSKAIDROJUMS

REF : ATSAUKSMES KODS

Izveido saĪkni starp detaĪu sarakstã un detaĪu uz attçla. “-” nozĪmç, ka detaĪa nav attçlota ilustrãcijã.

DETAĪAS NUMURS

Ja detaĪas numurs nav minçts, tad detaĪu nevar iegūt kã rezerves daĪu. Ar punktu apzĪmçtãs detaĪas ir mezgla sastãvdaĪas, kurð ir attçlots tieði virs tãm.

APZĪMÇJUMS

Parasti tas ir detaĪas nosaukums. Standarta detaĪãm, papildus nosaukumam, tiek minçta virkne raksturojumu \ specifikãciju.

QTY : DAUDZUMS

Norãda domãtãs detaĪas daudzumu. “AR” nozĪmç “As Required” – “kã nepiecieðams”.

SERVICE PAK

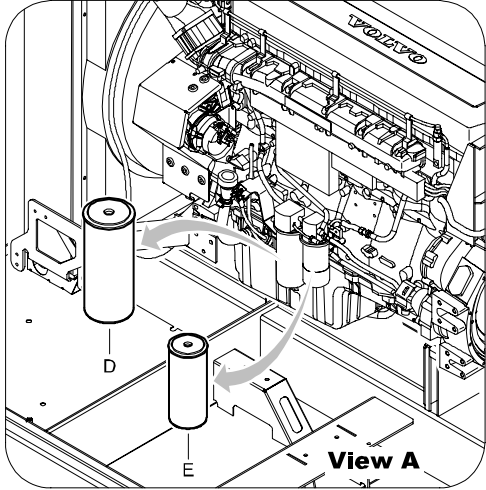
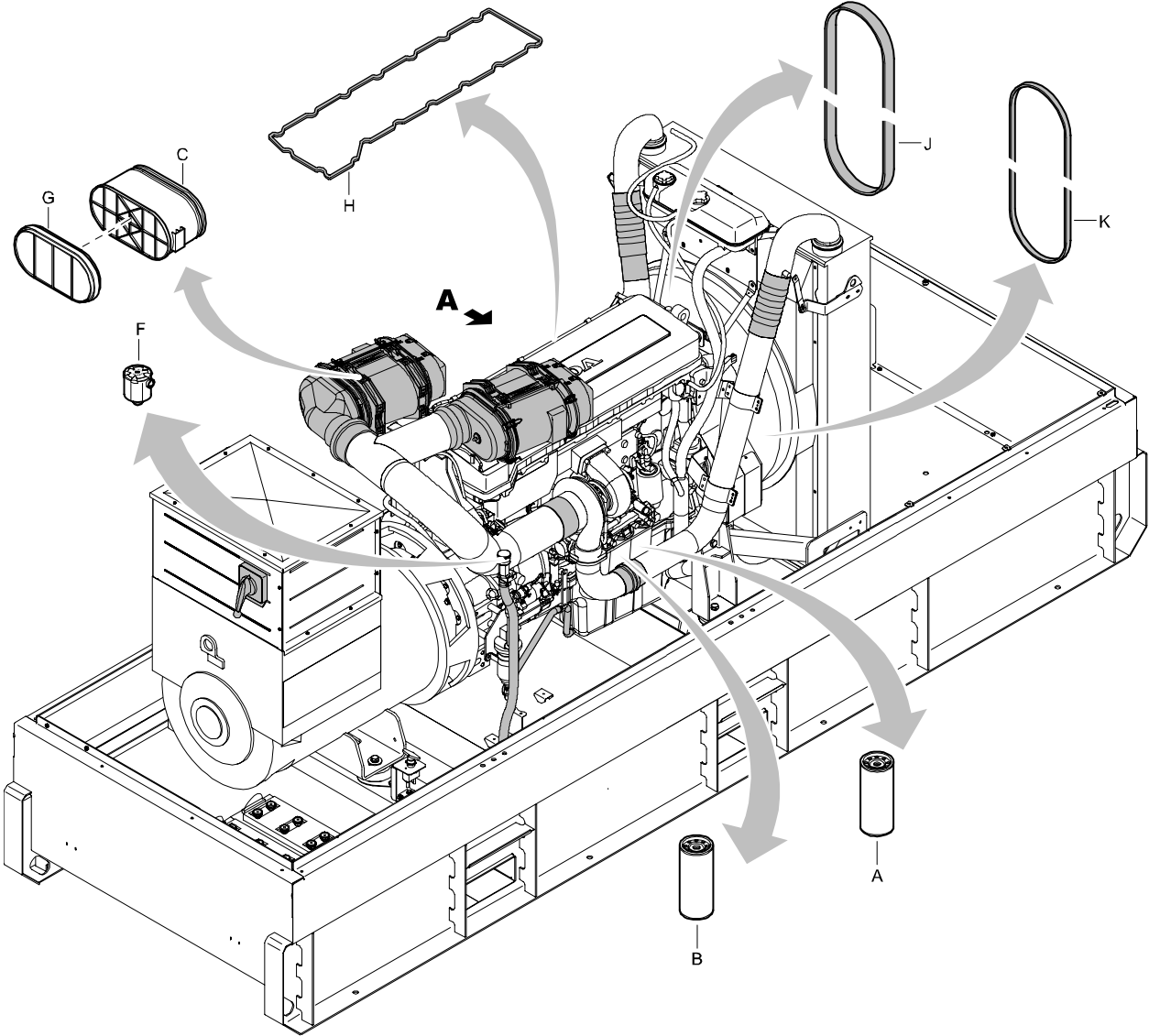

SERVICE PAK

REF	PART NUMBER	DESIGNATION	QTY	REF	PART NUMBER	DESIGNATION	QTY	REF	PART NUMBER	DESIGNATION	QTY
A	2914 9847 00	OILFILTER	2								
B	2914 9603 00	OILFILTER	1								
-	2912 4505 04	SERVICE PAK 500H									
•A	-	OILFILTER	2								
•B	-	OILFILTER	1								
•C	-	AIRFILTER	2								
-	2912 4506 05	SERVICE PAK 1000H									
•A	-	OILFILTER	2								
•B	-	OILFILTER	1								
•C	-	AIRFILTER	2								
•D	-	FUELFILTER	1								
•E	-	WATER/FUEL FILTER	1								
•F	-	FUELTANK VENTING FILTER	1								
-	2912 4507 06	SERVICE PAK 2000H									
•A	-	OILFILTER	2								
•B	-	OILFILTER	1								
•C	-	AIRFILTER	2								
•D	-	FUELFILTER	1								
•E	-	WATER/FUEL FILTER	1								
•F	-	FUELTANK VENTING FILTER	1								
•G	-	SAFETY CARTRIDGE	2								
•H	-	ROCKER COVER GASKET	1								
•J	-	ALTERNATOR BELT	1								
•K	-	FANBELT	1								

ENGINE OIL - PAROIL 5W40

REF	PART NUMBER	DESIGNATION	QTY
A	1604 6060 01	PAROIL 5W40 5 LITER CAN	1
B	1604 6059 01	PAROIL 5W40 20 LITER CAN	1



ENGINE OIL - PAROIL 15W40

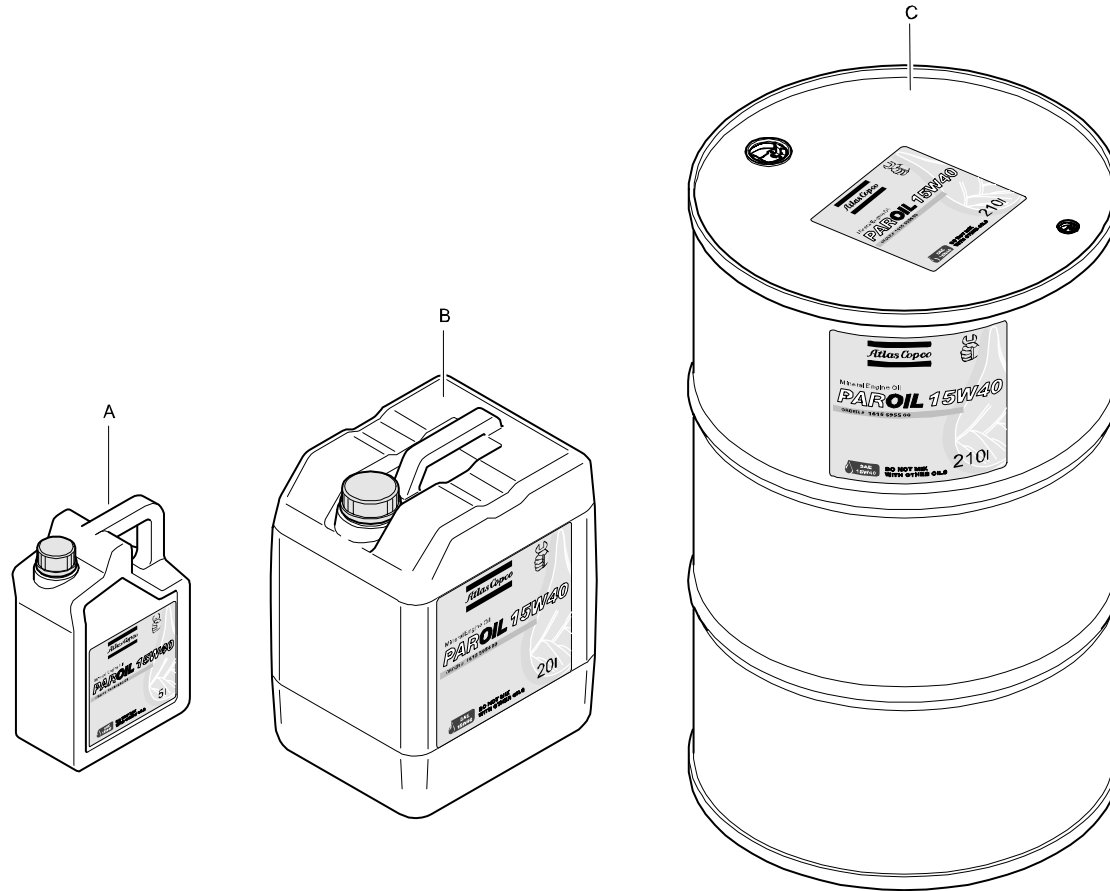

REF	PART NUMBER	DESIGNATION	QTY
A	1615 5953 00	PAROIL 15W40 5 LITER CAN	1
B	1615 5954 00	PAROIL 15W40 20 LITER CAN	1
C	1615 5955 00	PAROIL 15W40 210 LITER BARREL	1

ENGINE COOLANT - PARCOOL EG

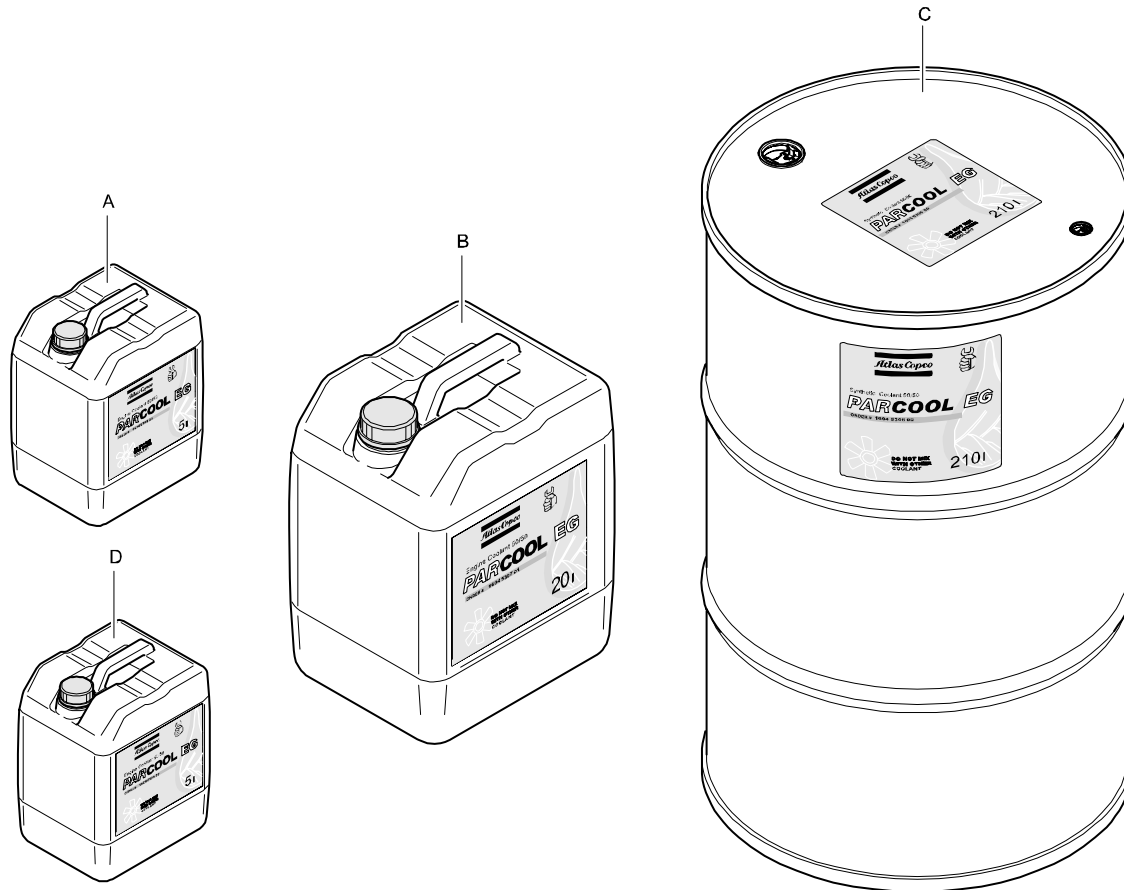

REF	PART NUMBER	DESIGNATION	QTY
A	1604 5308 00	PARCOOL EG 5 LITER CAN	1
B	1604 5307 01	PARCOOL EG 20 LITER CAN	1
C	1604 5306 00	PARCOOL EG 210 LITER BARREL	1
D	1604 8159 00	PARCOOL EG CONCENTRATE 5 LITER CAN	1

PLUGS FOR 3 WAY VALVE - FOR GENERATOR WITHOUT EXTERNAL FUELTANK CONNECTION - STANDARD

REF	PART NUMBER	DESIGNATION	QTY
20	0686 3716 02	HEXAGON PLUG	2
25	0653 1124 00	FLAT GASKET	2

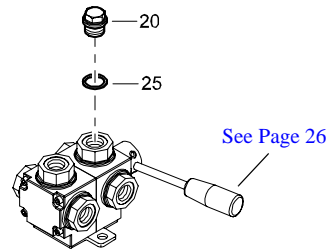

AIR INLET - STANDARD

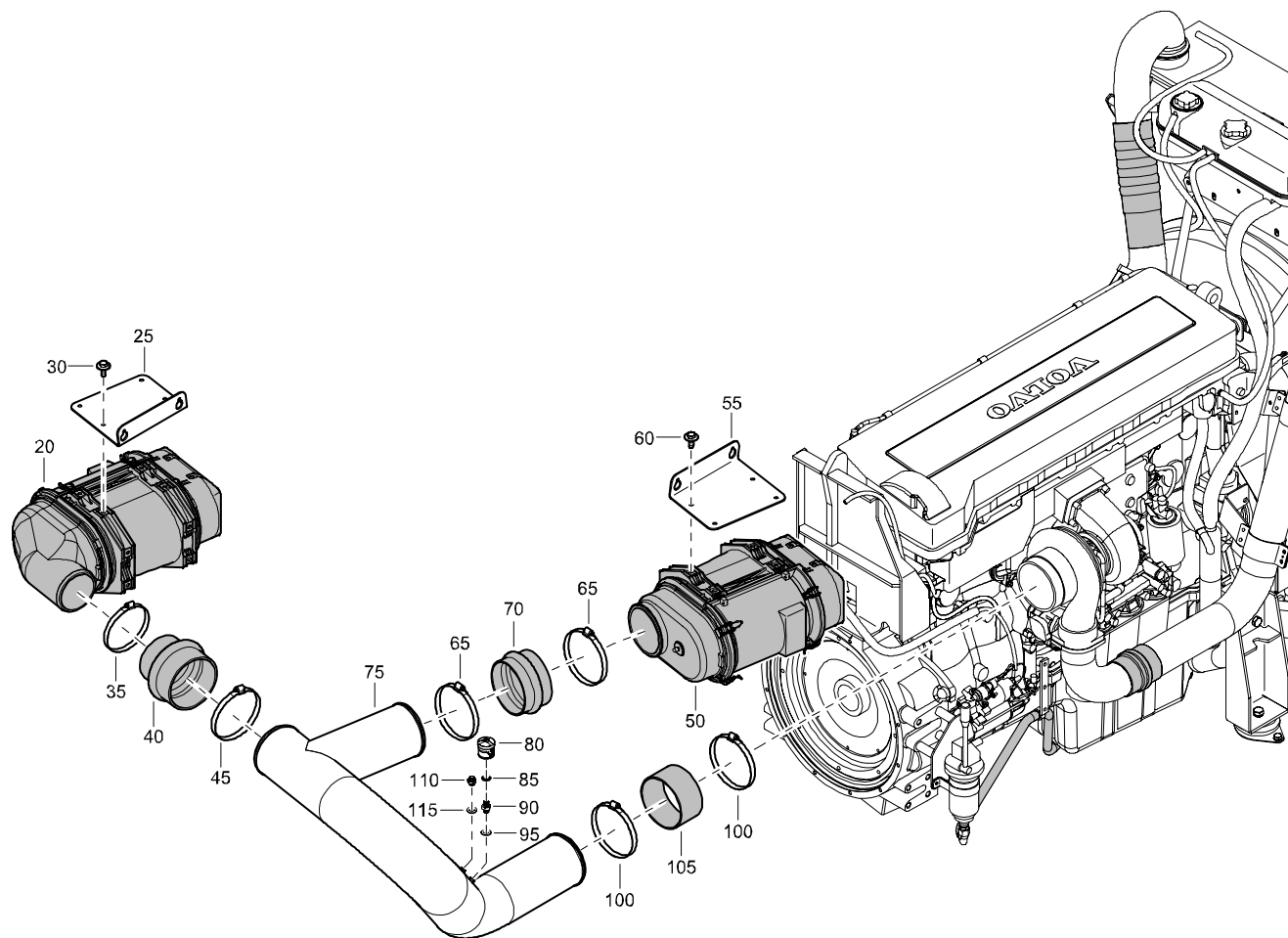

REF	PART NUMBER	DESIGNATION	QTY
20	1626 4282 00	FILTER AIR	1
25	1626 4348 00	SUPPORT	1
30	1615 5664 00	HEX. HEAD SCREW	6
35	0347 6120 00	HOSE CLAMP	1
40	1604 5756 00	HOSE	1
45	0347 6121 00	HOSE CLAMP	1
50	1626 4283 00	FILTER AIR	1
55	1626 4348 00	SUPPORT	1
60	1615 5664 00	HEX. HEAD SCREW	6
65	0347 6121 00	HOSE CLAMP	2
70	1604 9936 00	HUMP HOSE	1
75	1626 4347 00	DUCT	1
80	1613 7912 01	INDICATOR	1
85	0661 1014 00	SEALING WASHER	1
90	1612 2152 00	NIPPLE	1
95	0653 1046 00	FLAT GASKET	1
100	0347 6121 00	HOSE CLAMP	2
105	1604 3730 01	HOSE	1
110	0603 4300 07	HEXAGON NIPPLE	1
115	0653 1046 00	FLAT GASKET	1

ALTERNATOR - 230V/400V - STANDARD

REF	PART NUMBER	DESIGNATION	QTY
20	1626 2122 00	ALTERNATOR	1

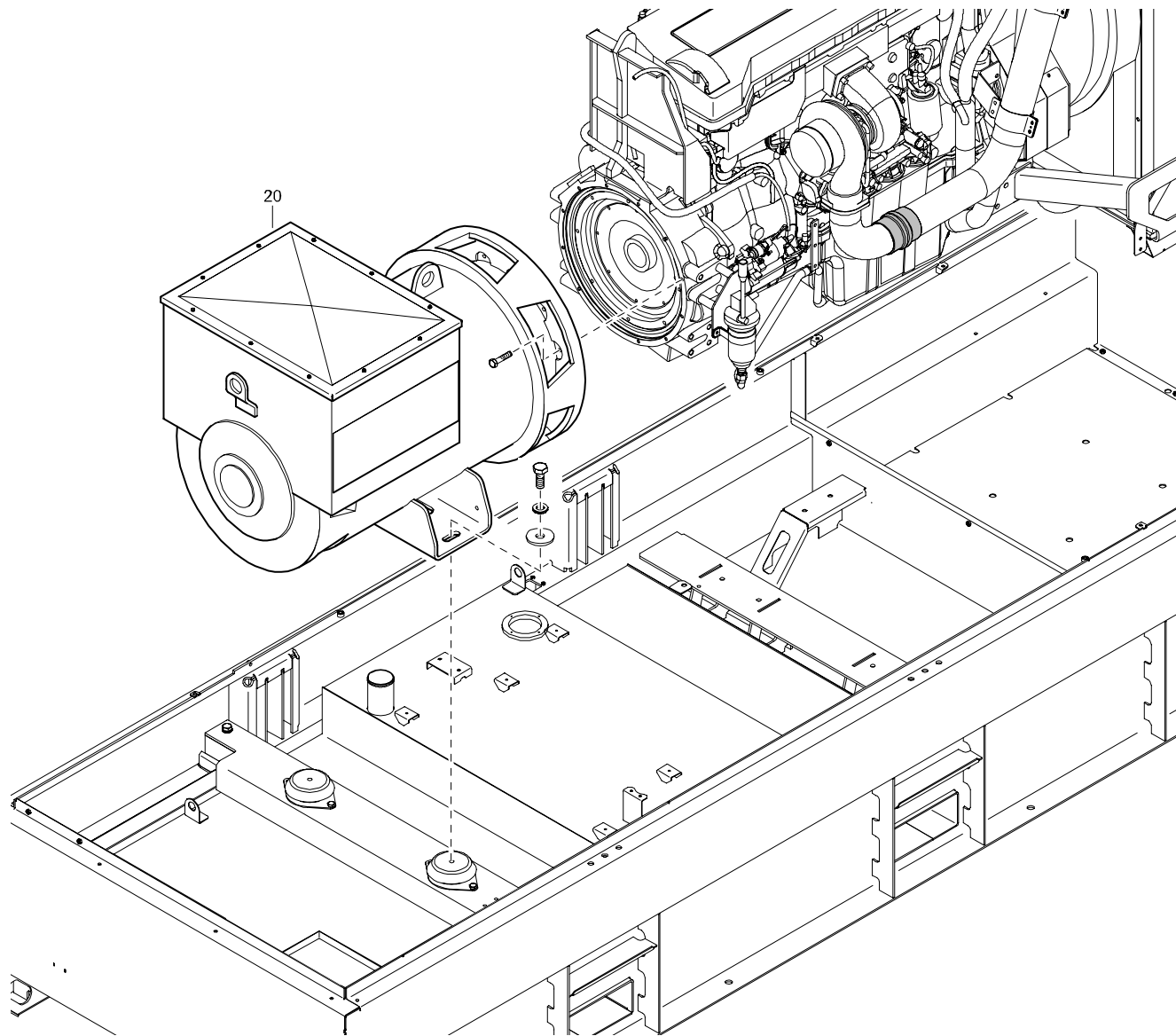

FUEL SYSTEM - STANDARD

REF	PART NUMBER	DESIGNATION	QTY	REF	PART NUMBER	DESIGNATION	QTY	REF	PART NUMBER	DESIGNATION	QTY
20	1626 2118 01	TANK FUEL	1	230	0653 1124 00	FLAT GASKET	1				
21	0686 3716 07	HEXAGON PLUG	1	235	1079 5840 35	NIPPLE	1				
22	0653 1189 00	FLAT GASKET	1	240	1604 2799 00	ELBOW	1				
25	1626 3785 00	HOSE	1	245	0075 4025 42	FUEL HOSE	AR				
30	0347 6131 00	HOSE CLAMP	2	250	1604 1384 00	HOSE NIPPLE	1				
35	1615 5664 00	HEX. HEAD SCREW	4	255	3176 3829 00	NIPPLE	1				
40	1615 6947 02	COVER	1	260	0347 6110 00	HOSE CLAMP	1				
45	1604 4344 00	FLANGE	1	265	0075 4025 23	FUEL HOSE	AR				
50	1604 4345 00	GASKET	1	270	0346 1000 15	PIPE CLAMP	1				
55	1619 5898 01	HEX. HEAD SCREW	4	275	0347 6110 00	HOSE CLAMP	1				
70	0147 1213 03	HEX. HEAD SCREW	5	280	1626 3895 01	BRACKET	1				
75	0301 2318 00	PLAIN WASHER	5	285	1626 0264 80	NIPPLE ASSY.	1				
80	1626 0219 02	MANIFOLD	1	•A10	1626 0264 00	NIPPLE	1				
85	0075 4025 44	HOSE	AR	•A20	1626 0265 00	NIPPLE	1				
90	0347 6106 00	HOSE CLAMP	1	•A30	1626 0266 00	WASHER	1				
95	1604 2780 02	GASKET	1	•A40	0517 1100 31	BEARING BALL	1				
100	1619 5898 01	HEX. HEAD SCREW	4	290	1626 0375 00	FILTER	1				
105	1604 2780 02	GASKET	2	•B10	2914 9975 00	FILTER ELEMENT	1				
110	1604 2783 01	FLANGE	2								
115	1619 5898 01	HEX. HEAD SCREW	8								
120	1604 6111 01	VALVE	1								
125	1619 2766 00	HEX. HEAD SCREW	2								
130	0346 1002 05	PIPE CLAMP	6								
135	0147 1247 03	HEX. HEAD SCREW	3								
140	0301 2321 00	PLAIN WASHER	6								
145	0266 2108 00	HEXAGON NUT	3								
150	3176 3829 00	NIPPLE	1								
155	1604 1384 00	HOSE NIPPLE	1								
160	0075 4025 42	FUEL HOSE	AR								
165	1604 2799 00	ELBOW	1								
170	1079 5840 35	NIPPLE	1								
175	0653 1124 00	FLAT GASKET	1								
180	0653 1124 00	FLAT GASKET	1								
185	1079 5840 35	NIPPLE	1								
190	1604 2799 00	ELBOW	1								
195	0075 4025 42	FUEL HOSE	AR								
200	0347 6103 00	HOSE CLAMP	1								
205	0347 6103 00	HOSE CLAMP	1								
210	0075 4025 67	FLEXIBLE HOSE	AR								
215	0571 0020 99	FITTING PIPE	1								
220	1079 5840 19	HEXAGON NIPPLE	1								
225	0653 1124 00	FLAT GASKET	1								

FRAME AND MOUNTS - STANDARD

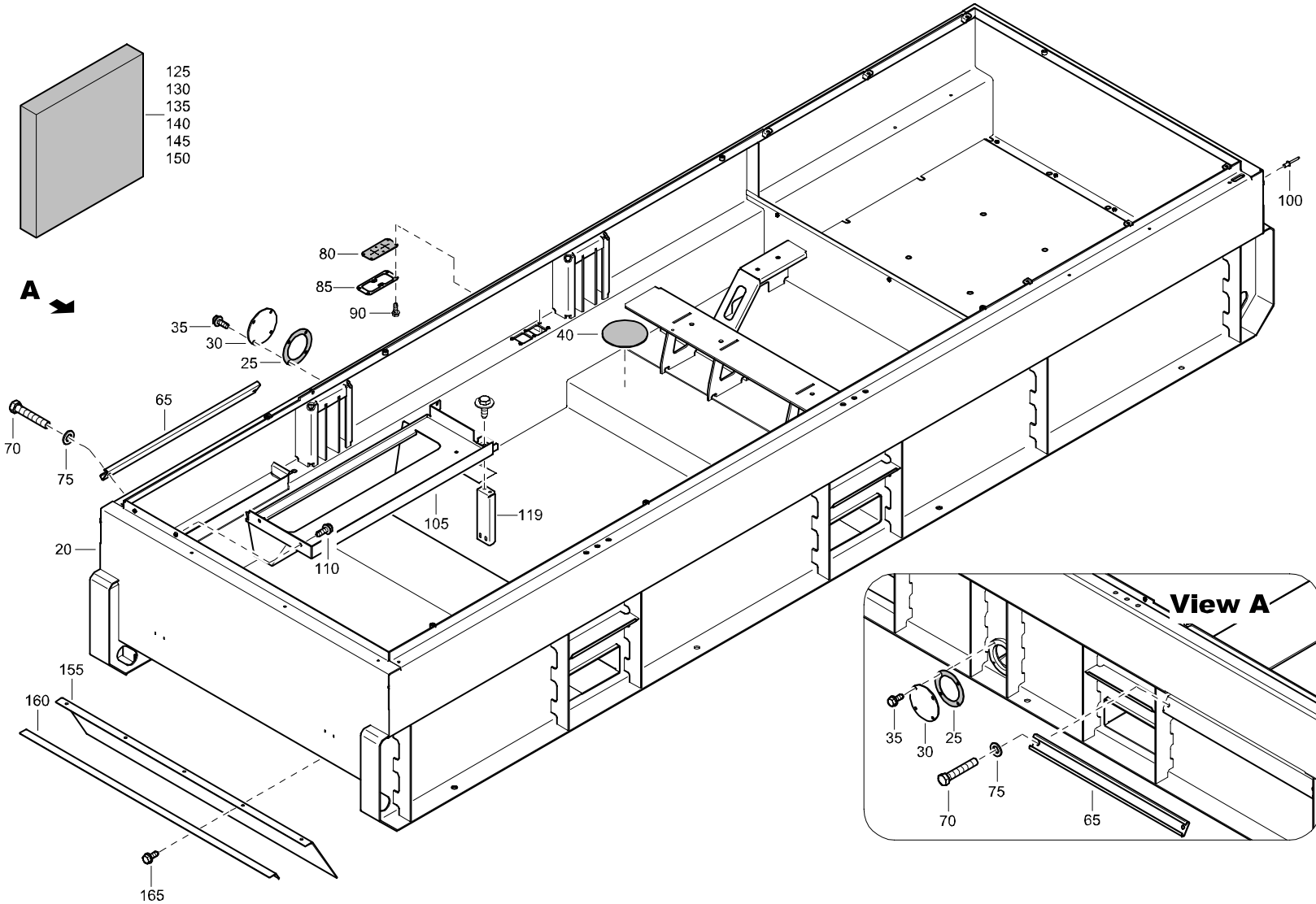
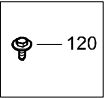

FRAME AND MOUNTS - STANDARD

REF	PART NUMBER	DESIGNATION	QTY	REF	PART NUMBER	DESIGNATION	QTY	REF	PART NUMBER	DESIGNATION	QTY
20	1626 2120 01	FRAME	1								
25	1604 6550 00	GASKET	1								
30	1604 6551 01	FLANGE	1								
35	1619 2766 00	HEX. HEAD SCREW	4								
40	1626 1805 00	SEAL	6								
65	1626 3568 00	CLAMP	1								
70	0147 1961 35	SCREW	2								
75	0301 2358 00	PLAIN WASHER	2								
80	1626 0594 01	SEAL	1								
85	1626 0595 01	PLATE	1								
90	1619 5898 01	HEX. HEAD SCREW	6								
100	0129 3270 34	BLIND RIVET	4								
105	1626 3566 01	SUPPORT	1								
110	1619 2766 00	HEX. HEAD SCREW	3								
119	1626 4179 00	SUPPORT	1								
120	1615 5664 00	HEX. HEAD SCREW	4								
125	-	INSULATION	1								
		SILENCING FOAM (50 mm)									
130	-	INSULATION	1								
		SILENCING FOAM (50 mm)									
135	-	INSULATION	2								
		SILENCING FOAM (50 mm)									
140	-	INSULATION	1								
		SILENCING FOAM (50 mm)									
145	-	INSULATION	2								
		SILENCING FOAM (50 mm)									
150	-	INSULATION	2								
		SILENCING FOAM (50 mm)									
155	1626 4234 00	SEAL	2								
160	1626 4235 00	PLATE	2								
165	1619 2766 00	HEX. HEAD SCREW	10								
-	1079 0003 33	SILENCING FOAM 2000 mm x 1500 mm x 50 mm									

ENGINE - STANDARD

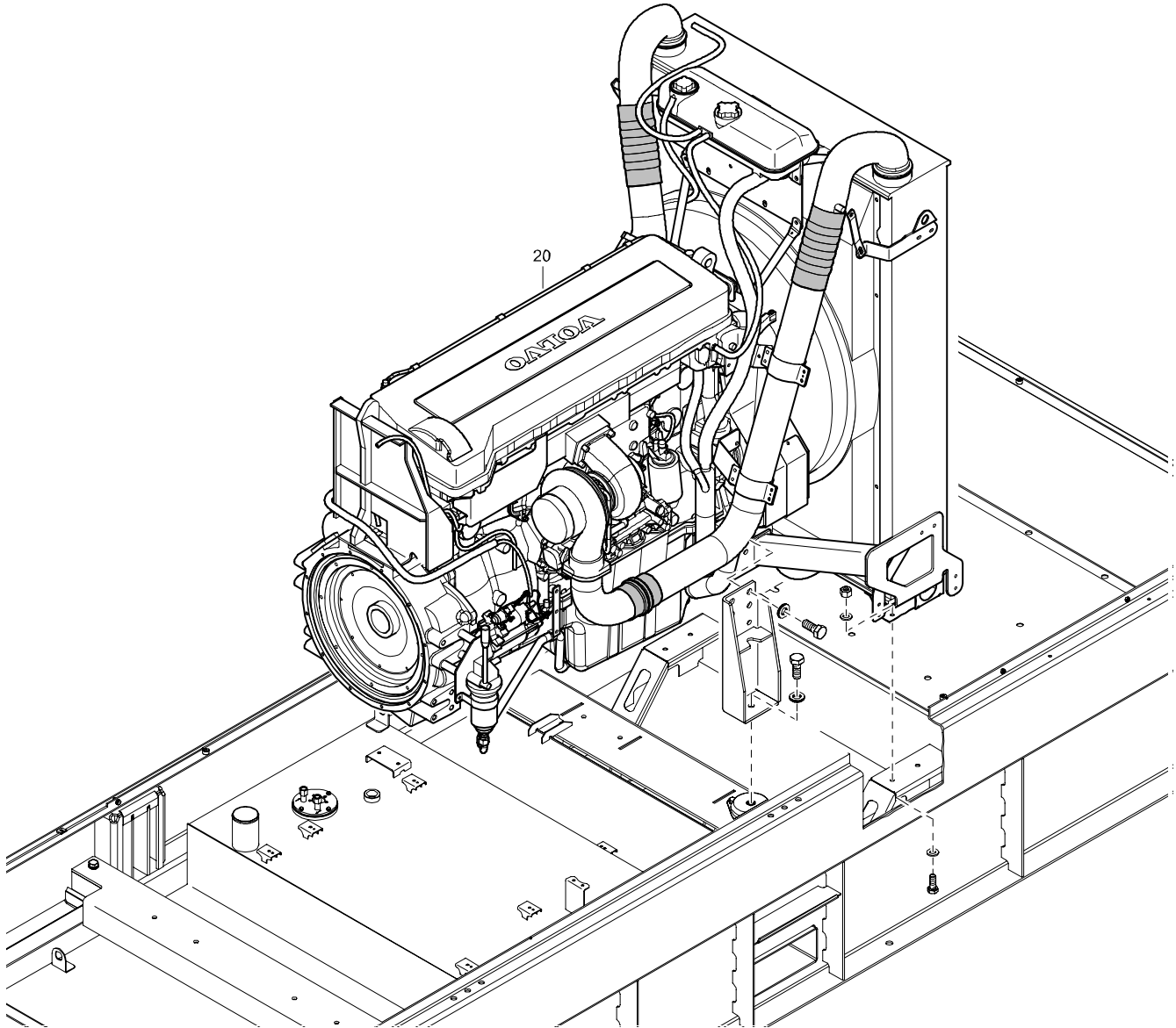

REF	PART NUMBER	DESIGNATION	QTY
20	1626 3648 01	ENGINE	1

FUEL LEVEL SENDER - STANDARD

REF	PART NUMBER	DESIGNATION	QTY
20	1626 3842 01	SENSOR LEVEL	1

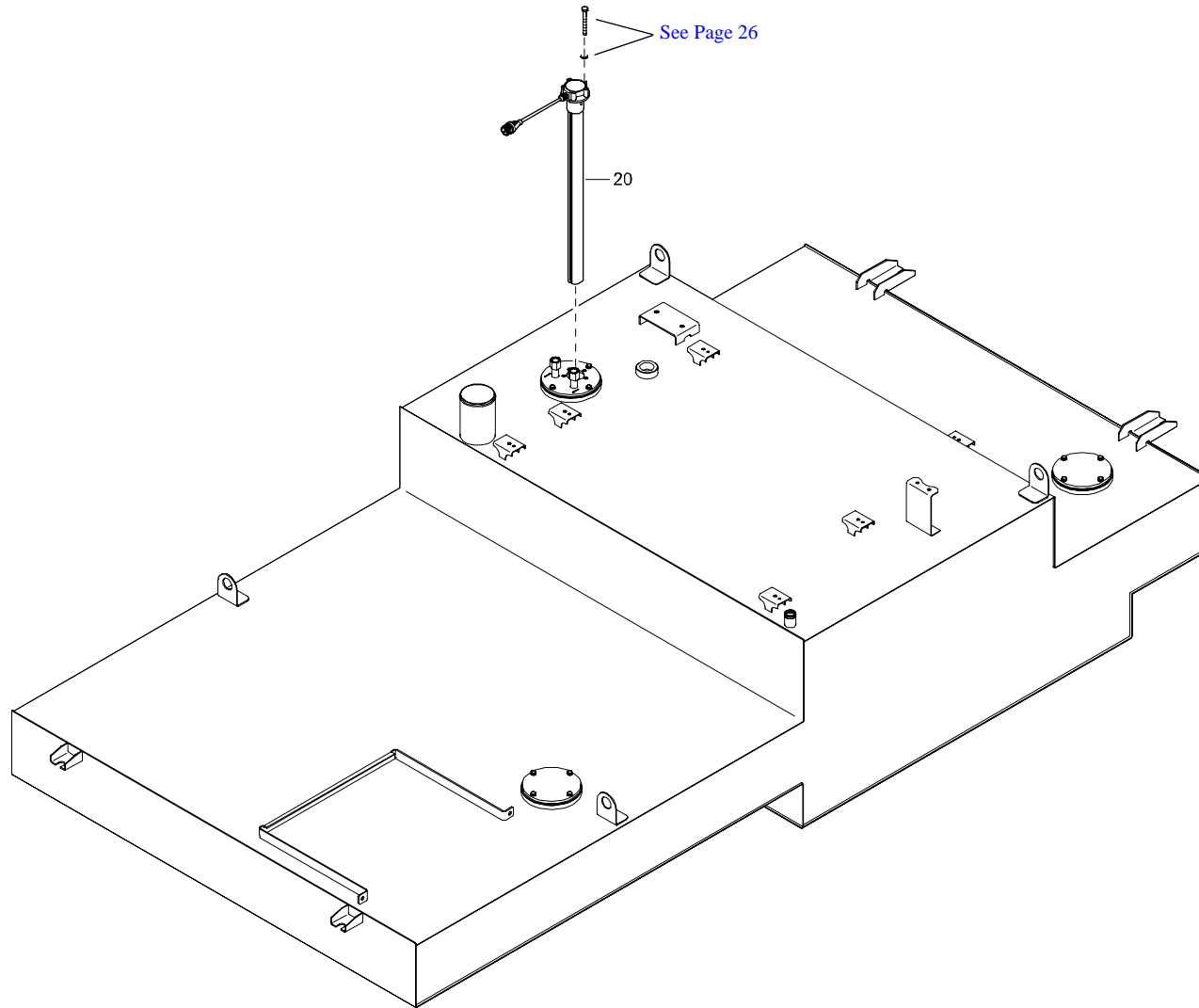

ALTERNATOR AND ACCESSORIES - 400V - STANDARD

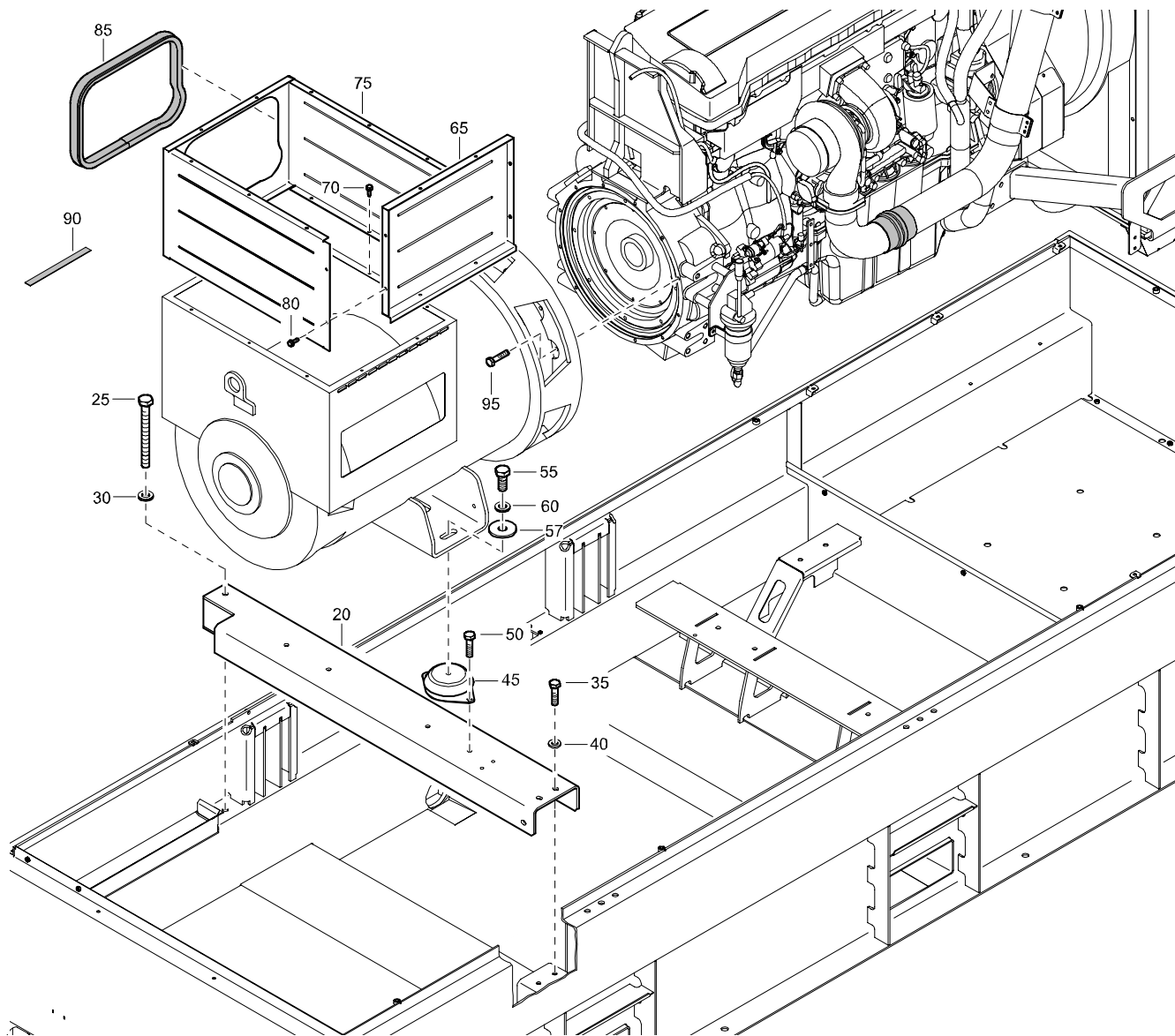

REF	PART NUMBER	DESIGNATION	QTY
20	1626 3569 01	SUPPORT	1
25	0147 1495 03	HEX. HEAD SCREW	1
30	0333 5200 08	WASHER	1
35	0147 1403 03	HEX. HEAD SCREW	3
40	0333 5200 09	LOCK WASHER	3
45	1020 5072 00	RUBBER BUFFER	2
50	0147 1403 03	HEX. HEAD SCREW	4
55	0147 1477 03	HEX. HEAD SCREW	2
57	0300 0274 96	PLAIN WASHER	2
60	0333 5200 08	WASHER	2
65	1626 3171 01	PLATE	1
70	1619 5898 01	HEX. HEAD SCREW	6
75	1626 3170 01	PLATE	1
80	1619 5898 01	HEX. HEAD SCREW	8
85	1626 4256 00	SEAL	AR
90	1615 7057 00	SEAL	AR
95	0147 1962 64	BOLT	12

ALTERNATOR AND ACCESSORIES - 230V/400V -STANDARD

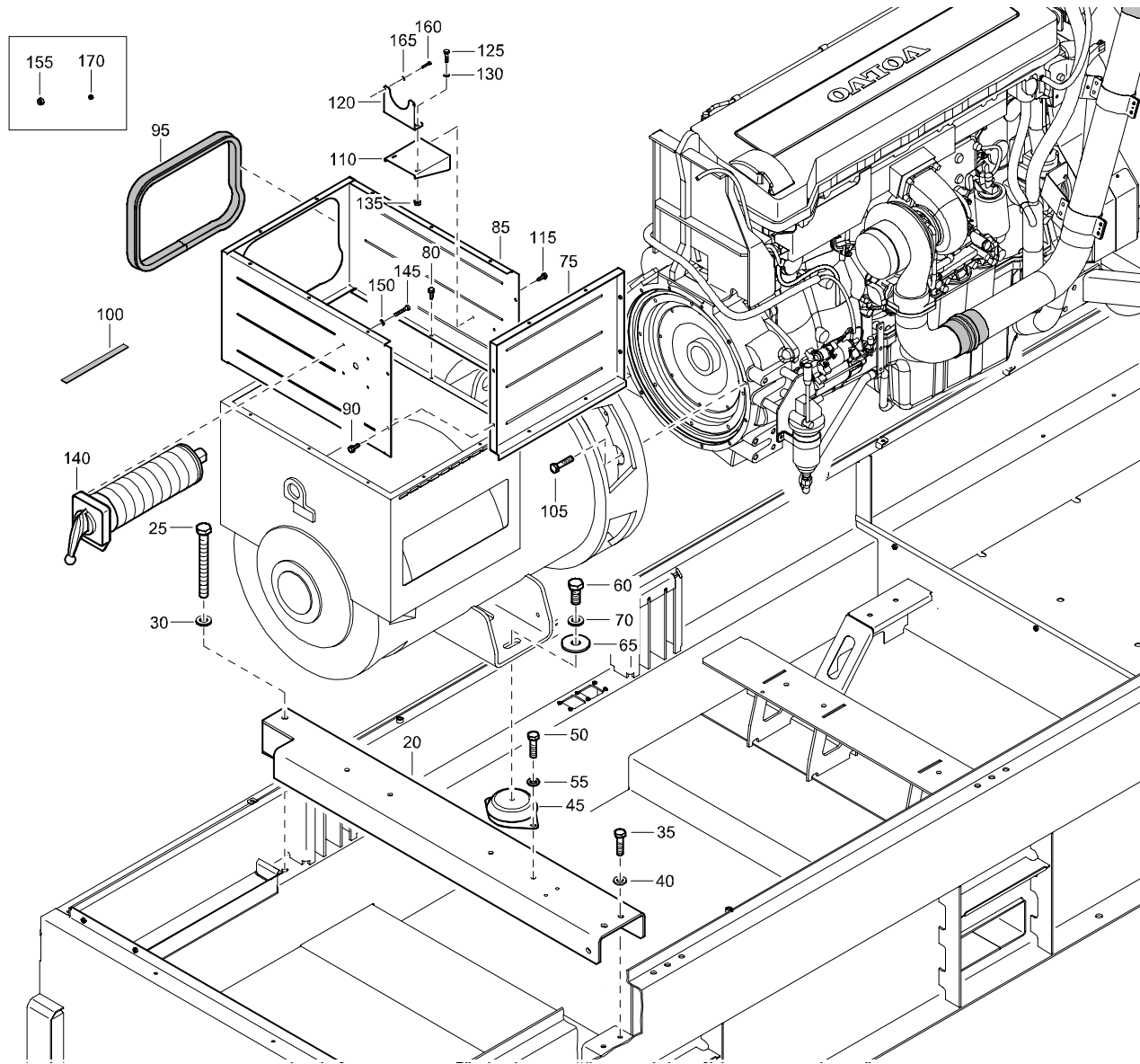

REF	PART NUMBER	DESIGNATION	QTY
20	1626 3569 01	SUPPORT	1
25	0147 1495 03	HEX. HEAD SCREW	1
30	0333 5200 08	WASHER	1
35	0147 1403 03	HEX. HEAD SCREW	3
40	0333 5200 09	LOCK WASHER	3
45	1020 5072 00	RUBBER BUFFER	2
50	0147 1403 03	HEX. HEAD SCREW	4
55	0301 2358 00	PLAIN WASHER	4
60	0147 1477 03	HEX. HEAD SCREW	2
65	0300 0274 96	PLAIN WASHER	2
70	0333 5200 08	WASHER	2
75	1626 3171 01	PLATE	1
80	1619 5898 01	HEX. HEAD SCREW	6
85	1626 4158 00	BOX	1
90	1619 5898 01	HEX. HEAD SCREW	8
95	1626 4256 00	SEAL	AR
100	1615 7057 00	SEAL	AR
105	0147 1962 64	BOLT	12
110	1626 4164 00	SUPPORT	1
115	1619 5898 01	HEX. HEAD SCREW	2
120	1626 4165 00	SUPPORT	1
125	0147 1247 03	HEX. HEAD SCREW	2
130	0301 2321 00	PLAIN WASHER	4
135	0291 1108 00	LOCKNUT	2
140	1089 9082 50	SWITCH	1
145	0160 6088 00	SCREW SLOTTED	4
150	0301 2321 00	PLAIN WASHER	8
155	0291 1108 00	LOCKNUT	4
160	0160 6043 00	SLOTTED SCREW	2
165	0301 2315 00	PLAIN WASHER	4
170	0291 1106 00	LOCKNUT	2

EXHAUST - STANDARD

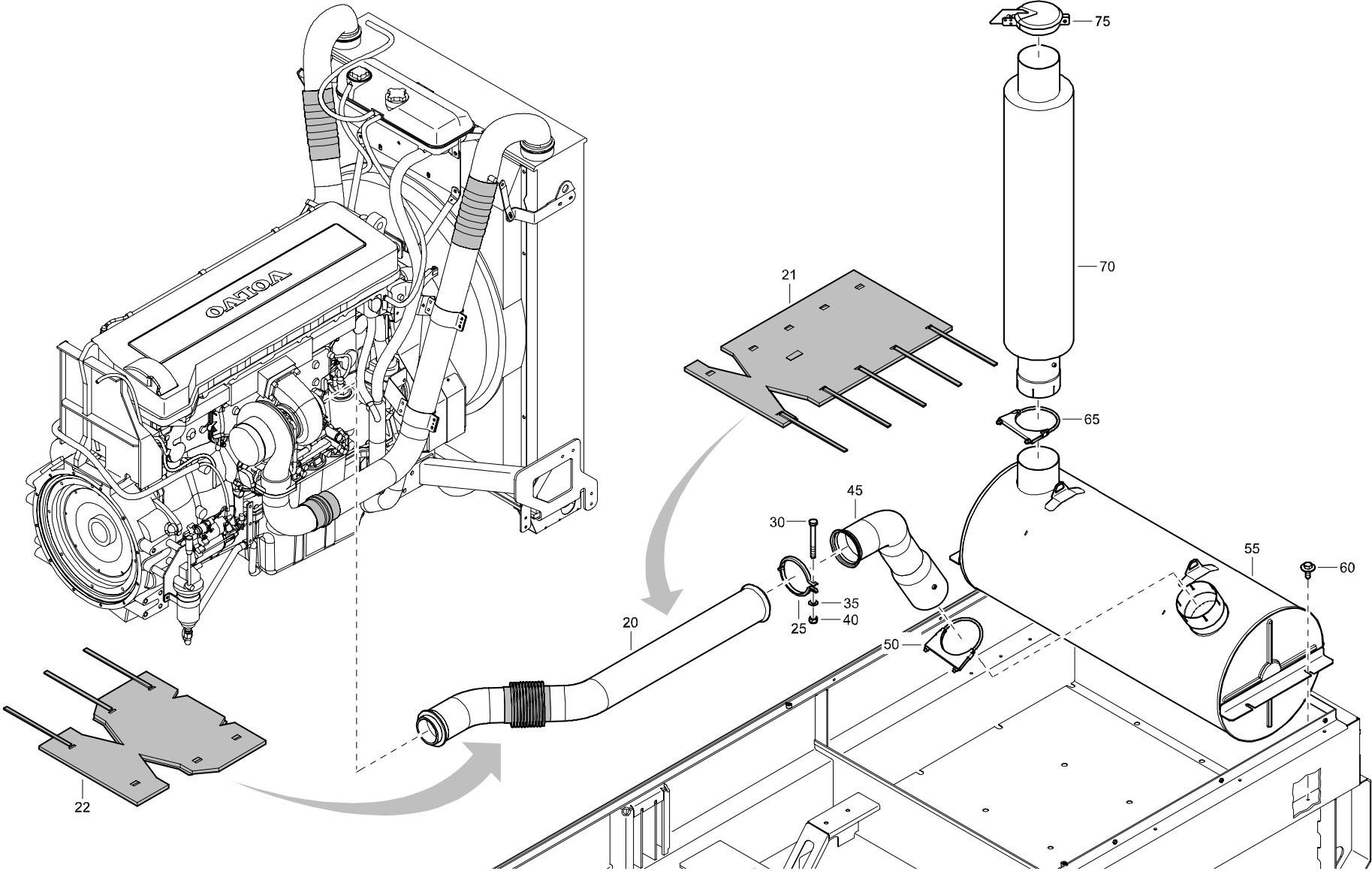

EXHAUST - STANDARD

REF	PART NUMBER	DESIGNATION	QTY	REF	PART NUMBER	DESIGNATION	QTY	REF	PART NUMBER	DESIGNATION	QTY
20	1626 3044 02	PIPE EXHAUST	1								
21	1626 4265 00	INSULATION	1								
22	1626 4266 00	INSULATION	1								
25	1604 2548 00	CLAMP	1								
30	0147 1963 95	HEX. HEAD SCREW	1								
35	0301 2335 00	PLAIN WASHER	1								
40	0291 1185 04	LOCKNUT	1								
45	1626 3045 01	PIPE EXHAUST	1								
50	1604 5606 00	CLAMP	1								
55	1626 3046 02	MUFFLER	1								
60	1615 5664 00	HEX. HEAD SCREW	4								
65	1604 5606 00	CLAMP	1								
70	1626 3047 01	PIPE EXHAUST	1								
75	1626 3859 00	CAP	1								

COOLING SYSTEM - STANDARD

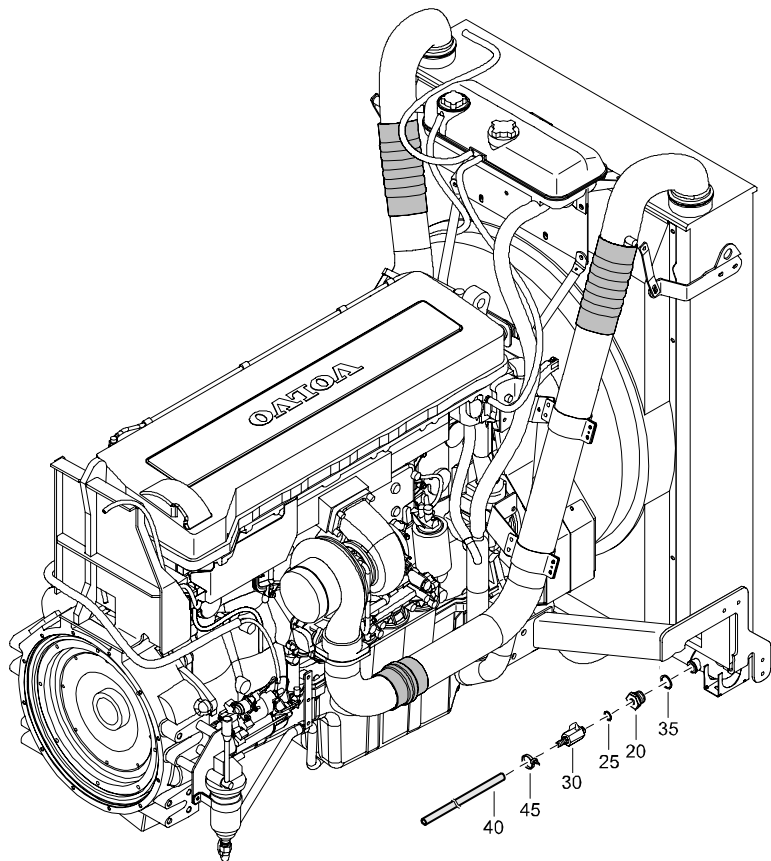

REF	PART NUMBER	DESIGNATION	QTY
20	1626 3312 00	NIPPLE HEXAGON	1
25	0653 1070 00	FLAT GASKET	1
30	1615 7072 00	VALVE	1
35	0653 1128 00	GASKET	1
40	0099 9910 29	PLASTIC TUBE	AR
45	1088 1301 03	CABLE STRIP	3

OIL SYSTEM - DRAIN - STANDARD

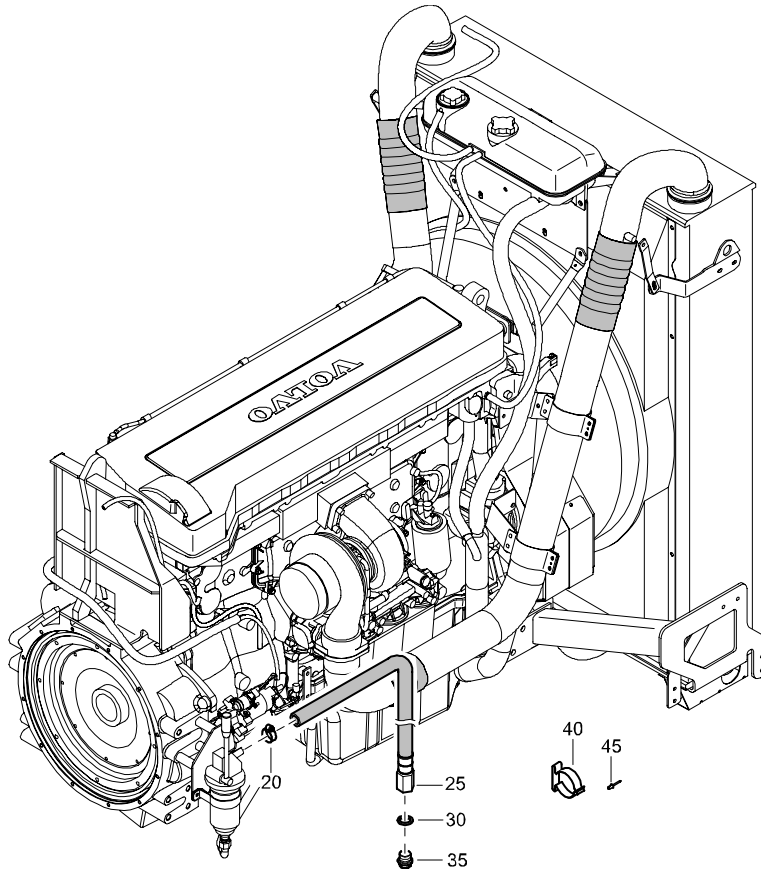

REF	PART NUMBER	DESIGNATION	QTY
20	0347 6106 00	HOSE CLAMP	1
25	1626 4186 00	HOSE ASSEMBLY	1
30	0661 1030 00	SEALING WASHER	1
35	0686 3716 02	HEXAGON PLUG	1
40	1079 3461 02	HOSE CLIP	1
45	0129 3107 00	BLIND RIVET	1

ELECTRICAL SYSTEM - STANDARD

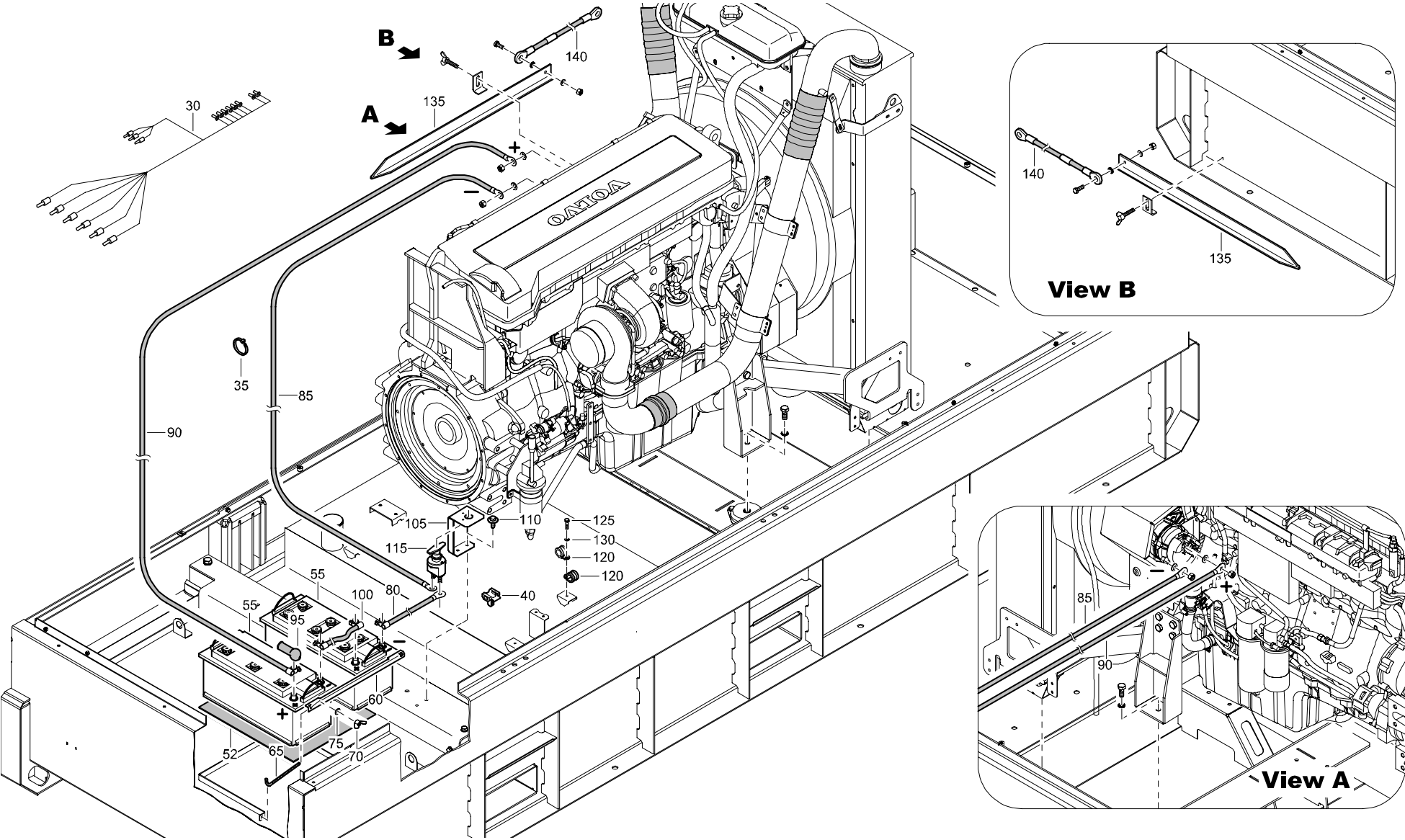

ELECTRICAL SYSTEM - STANDARD

REF	PART NUMBER	DESIGNATION	QTY	REF	PART NUMBER	DESIGNATION	QTY	REF	PART NUMBER	DESIGNATION	QTY
30	1626 3841 01	WIRING	1								
35	1088 1301 03	CABLE STRIP	7								
40	0348 0110 13	PAD	7								
52	1626 4233 00	PAD	1								
55	0975 8300 16	BATTERY	2								
60	1626 2127 00	BRACKET	1								
65	1626 0527 00	HOOK	2								
70	0296 1110 02	WING NUT	2								
75	0301 2335 00	PLAIN WASHER	2								
80	1604 3272 00	BATTERY CABLE	1								
85	1626 3904 00	CABLE	1								
90	1615 6169 01	BATTERY CABLE	1								
95	1604 3329 00	PROTECTION CAP	1								
100	1604 6049 00	CABLE (ELEC)	1								
105	1626 3899 01	SUPPORT	1								
110	1615 5664 00	HEX. HEAD SCREW	2								
115	1089 0584 01	BATTERY SWITCH	1								
120	0346 1002 05	PIPE CLAMP	6								
125	0147 1247 03	HEX. HEAD SCREW	4								
130	0301 2321 00	PLAIN WASHER	4								
135	1089 9358 09	PIN	1								
140	1626 4272 00	CABLE	1								

BODYWORK - STANDARD

REF	PART NUMBER	DESIGNATION	QTY	REF	PART NUMBER	DESIGNATION	QTY	REF	PART NUMBER	DESIGNATION	QTY
5	1626 2126 81	BEAM (For details see page 59)	1	175	1619 2766 00	HEX. HEAD SCREW	4	310	1626 3554 81	DOOR	1
10	1626 2125 81	BEAM (For details see page 58)	2	180	1626 2139 81	CORNER (For details see page 62)	1	315	1626 2684 81	ROOF (For details see page 71)	1
15	0147 1477 03	HEX. HEAD SCREW	12	185	1619 2766 00	HEX. HEAD SCREW	4	320	1619 2766 00	HEX. HEAD SCREW	6
20	0333 5200 08	WASHER	12	190	1626 2813 01	PLATE	1	325	1626 3164 01	PLATE	1
25	1626 3174 00	PLATE	2	195	1615 5664 00	HEX. HEAD SCREW	21	330	1619 2766 00	HEX. HEAD SCREW	6
30	1619 2766 00	HEX. HEAD SCREW	4	196	-	INSULATION	1	335	1626 2683 81	ROOF	1
35	1626 3157 01	BEAM	2			SILENCING FOAM (50 mm)				(For details see page 74)	
36	-	INSULATION	4	197	-	INSULATION	1	340	1619 2766 00	HEX. HEAD SCREW	11
37	-	SILENCING FOAM (50 mm)		198	-	SILENCING FOAM (50 mm)	1	345	1626 3801 01	PLATE	1
		INSULATION	3			INSULATION		346	-	INSULATION	1
		SILENCING FOAM (50 mm)		200	1626 3158 01	PLATE	1			SILENCING FOAM (30 mm)	1
40	0147 1482 03	HEX. HEAD SCREW	6	205	1626 3932 01	PLATE	1	350	1619 2766 00	HEX. HEAD SCREW	6
45	0333 5200 08	WASHER	6	210	1615 5664 00	HEX. HEAD SCREW	2	355	1626 2661 81	ROOF	2
50	1626 2124 81	BEAM (For details see page 57)	1	215	1626 3173 01	SUPPORT	1			(For details see page 73)	
55	0147 1482 03	HEX. HEAD SCREW	3	220	1619 2766 00	HEX. HEAD SCREW	2	360	1619 2766 00	HEX. HEAD SCREW	8
60	0333 5200 08	WASHER	3	225	1626 3175 01	SUPPORT	1	365	1626 2129 81	ROOF	1
65	1626 3156 81	BEAM (For details see page 60)	1	230	1619 2766 00	HEX. HEAD SCREW	2			(For details see page 72)	
		INSULATION		235	1626 3176 01	SUPPORT	1	370	1619 2766 00	HEX. HEAD SCREW	8
		SILENCING FOAM (50 mm)		240	1619 2766 00	HEX. HEAD SCREW	2	371	0215 0003 77	HEX SOCK. SCREW	1
70	0147 1482 03	HEX. HEAD SCREW	3	245	1626 3172 01	SUPPORT	3	375	1626 3159 01	PROTECTION	1
75	0333 5200 08	WASHER	3	250	1619 2766 00	HEX. HEAD SCREW	9	380	0129 3172 01	RIVET	4
80	1626 2128 01	PLATE	4	255	1626 3567 81	BAFFLE	3	385	1626 3934 81	BAFFLE	3
85	0147 1477 03	HEX. HEAD SCREW	20			(For details see page 77)				(For details see page 78)	
90	0333 5200 08	WASHER	20	260	1626 3802 01	STAY	3	390	0147 1330 03	HEX. HEAD SCREW	6
115	1626 3163 00	SUPPORT	1	265	1619 2766 00	HEX. HEAD SCREW	6	395	0266 2110 00	HEXAGON NUT	6
120	1619 2766 00	HEX. HEAD SCREW	2	270	1626 2659 81	DOOR	1	400	0017 9861 53	PLASTIC BAG	1
125	1626 2818 81	BACKPLATE (For details see page 76)	3			(For details see page 68)					
		INSULATION		275	1619 2766 02	HEX. HEAD SCREW	3				
135	0301 2335 00	PLAIN WASHER	24	280	1626 2121 81	DOOR	1				
140	0266 2110 00	HEXAGON NUT	24			(For details see page 64)					
145	1604 5031 00	BRACKET	5	285	1626 2134 81	DOOR <BLANK>	1	-	1079 0003 32	SILENCING FOAM	
146	1626 2817 00	SPACER	5			(For details see page 65)				2000 mm x 1500 mm x 30 mm	
150	0215 0003 89	SCREW	10	290	1626 3552 81	DOOR	1	-	1079 0003 33	SILENCING FOAM	
155	0291 1108 00	LOCKNUT	10			(For details see page 69)				2000 mm x 1500 mm x 50 mm	
160	1626 2131 81	CORNER (For details see page 61)	1	295	1626 2136 81	DOOR	1				
		INSULATION				(For details see page 66)					
165	1619 2766 00	HEX. HEAD SCREW	4	300	1626 3553 81	DOOR	1				
166	0215 0003 77	HEX SOCK. SCREW	1			(For details see page 70)					
170	1626 3575 81	CORNER (For details see page 63)	1	305	1626 2655 81	DOOR	1				
		INSULATION				(For details see page 67)					

EARTH LEAKAGE RELAY - STANDARD

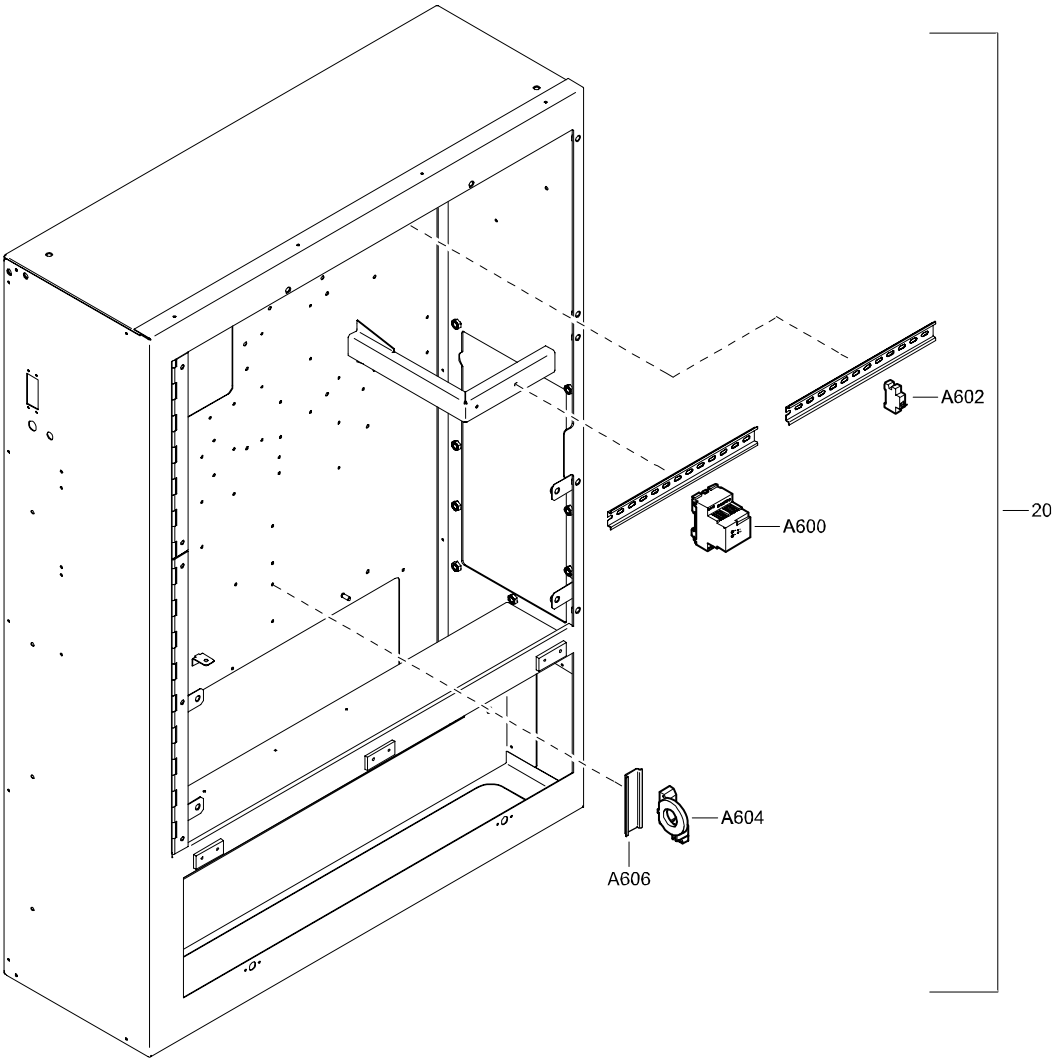

REF	PART NUMBER	DESIGNATION	QTY
20	1900 1036 60	RELAY	1
•A600	1089 9473 54	EARTH RELAY	1
•A602	1089 9473 20	SWITCH	1
•A604	1089 9473 55	TORUS	1
•A606	0993 7106 14	RAIL	1

DUAL FREQUENCY - STANDARD

REF	PART NUMBER	DESIGNATION	QTY
20	1900 1036 67	CONTROL SYSTEM	1
•A844	1089 9422 04	KEY SWITCH	1

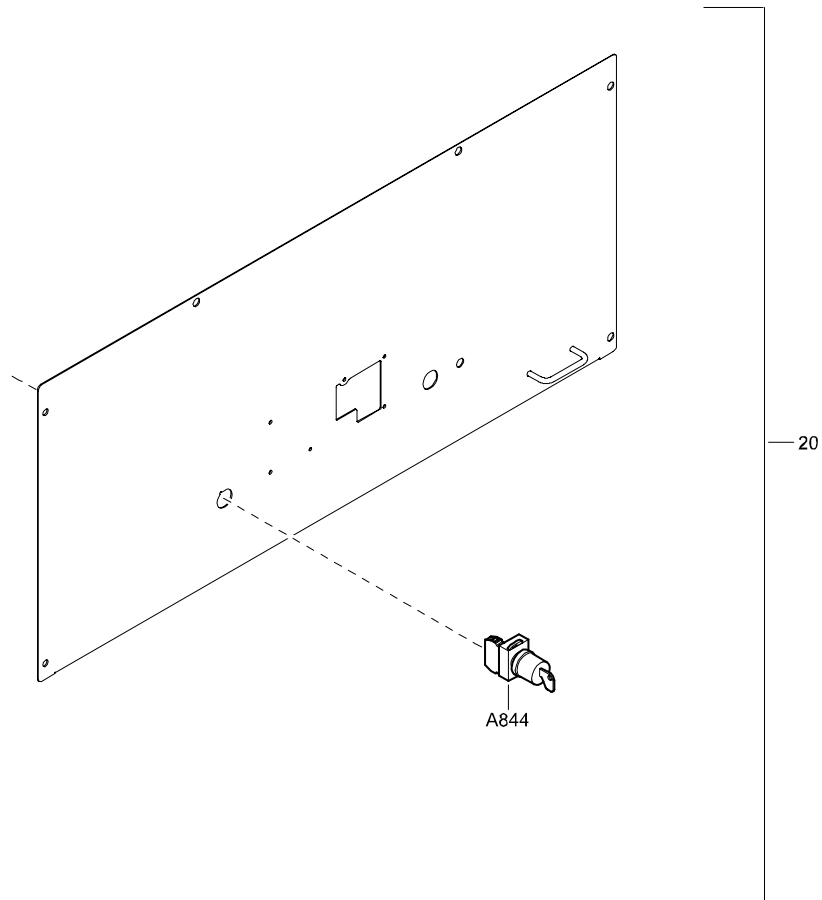

CONTROL PANEL - 400V - STANDARD

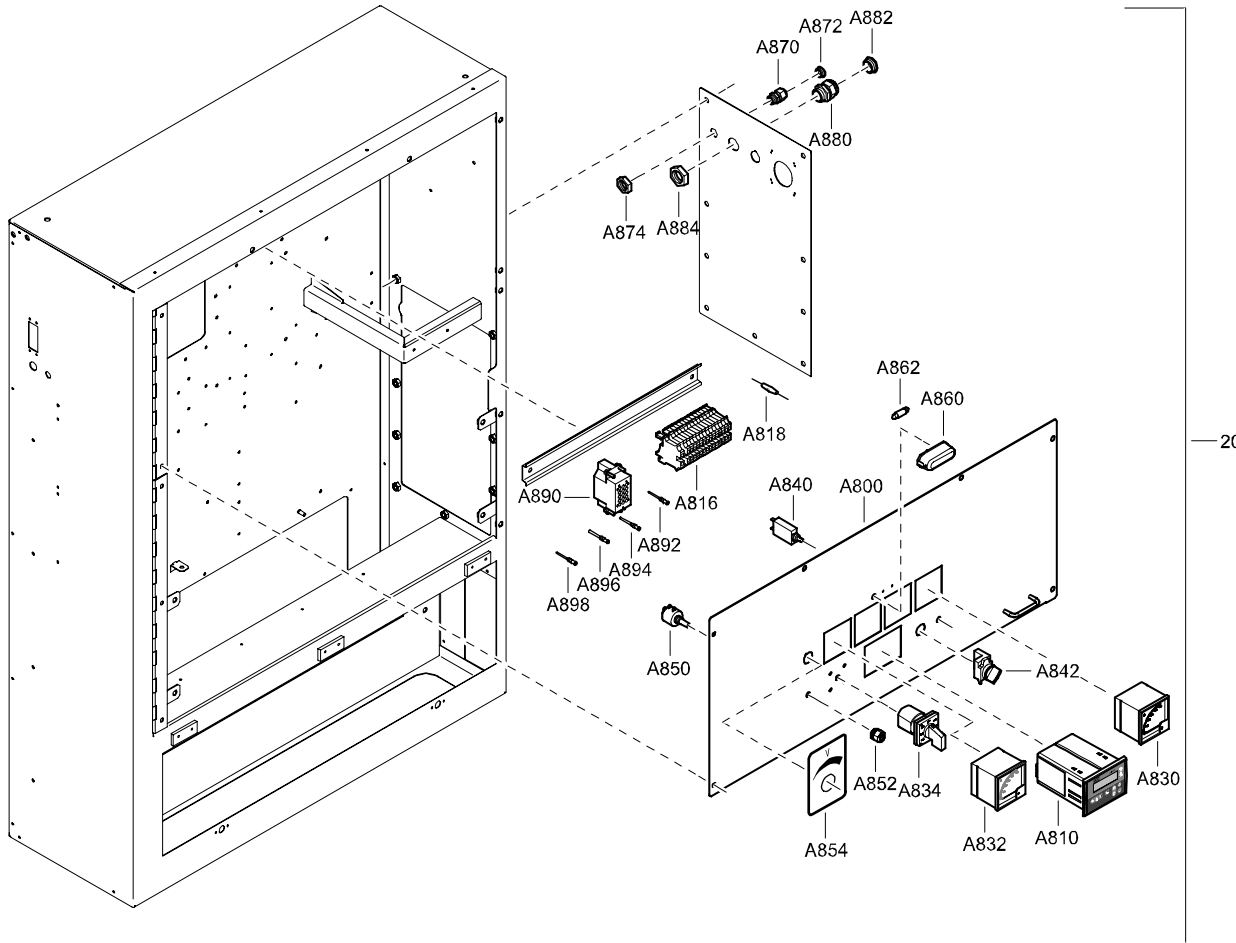

REF	PART NUMBER	DESIGNATION	QTY
20	1900 1036 85	CONTROL PANEL	1
•A800	1626 3608 01	PLATE	1
•A810	1604 9418 00	CONTROLLER	1
•A816	1089 0577 12	TERMINAL	15
•A818	1089 0310 29	RESISTOR	1
•A830	1089 9381 23	METER AMPERE	3
•A832	1089 9383 01	VOLTMETER	1
•A834	1089 9082 22	VOLTAGE SWITCH	1
•A840	1089 9423 01	CIRCUIT BREAKER	1
•A842	1089 0263 27	SELECTOR SWITCH	1
•A850	1089 9371 21	POTMETER	1
•A852	1089 9371 50	SPINDLE LOCK	1
•A854	1079 9909 20	LABEL	1
•A860	1089 9354 01	PANELLIGHT	1
•A862	1089 0374 01	LAMP	1
•A870	0698 5140 71	CABLE GLAND	1
•A872	0697 9810 58	PLUG	1
•A874	0697 9809 20	LOCK NUT	1
•A880	0698 5140 73	CABLE GLAND	1
•A882	0697 9810 61	PLUG	1
•A884	0697 9809 62	NUT	1
•A890	1088 0029 45	MALE INSERT	1
•A892	1088 0029 57	MALE CONTACT	2
•A894	1088 0029 61	MALE CONTACT	4
•A896	1088 0029 56	MALE CONTACT	1
•A898	1088 0029 55	MALE CONTACT	2

CONTROL PANEL - 230V/400V - STANDARD

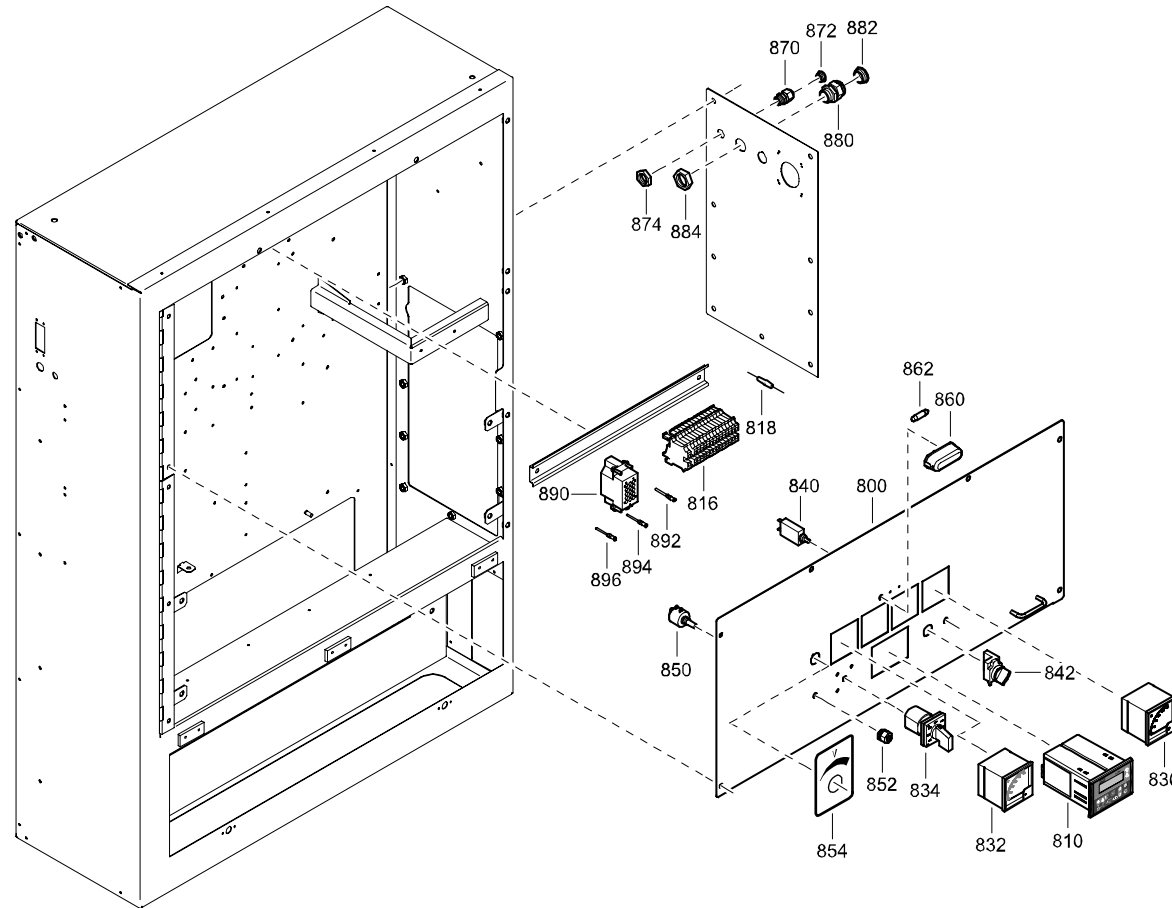

REF	PART NUMBER	DESIGNATION	QTY
800	1626 3608 01	PLATE	1
810	1604 9421 00	CONTROLLER	1
816	1089 0577 12	TERMINAL	19
818	1089 0310 29	RESISTOR	1
830	1089 9381 22	A-METER	3
832	1089 9383 01	VOLTMETER	1
834	1089 9082 22	VOLTAGE SWITCH	1
840	1089 9423 01	CIRCUIT BREAKER	1
842	1089 0263 27	SELECTOR SWITCH	1
850	1089 9371 21	POTMETER	1
852	1089 9371 50	SPINDLE LOCK	2
854	1079 9909 20	LABEL	1
860	1089 9354 01	PANELLIGHT	1
862	1089 0374 01	LAMP	1
870	0698 5140 71	CABLE GLAND	1
872	0697 9810 58	PLUG	1
874	0697 9809 20	LOCK NUT	1
880	0698 5140 73	CABLE GLAND	1
882	0697 9810 61	PLUG	1
884	0697 9809 22	LOCK NUT	1
890	1088 0029 45	MALE INSERT	1
892	1088 0029 57	MALE CONTACT	2
894	1088 0029 61	MALE CONTACT	4
896	1088 0029 56	MALE CONTACT	2

ENGINE AND ACCESSORIES - STANDARD

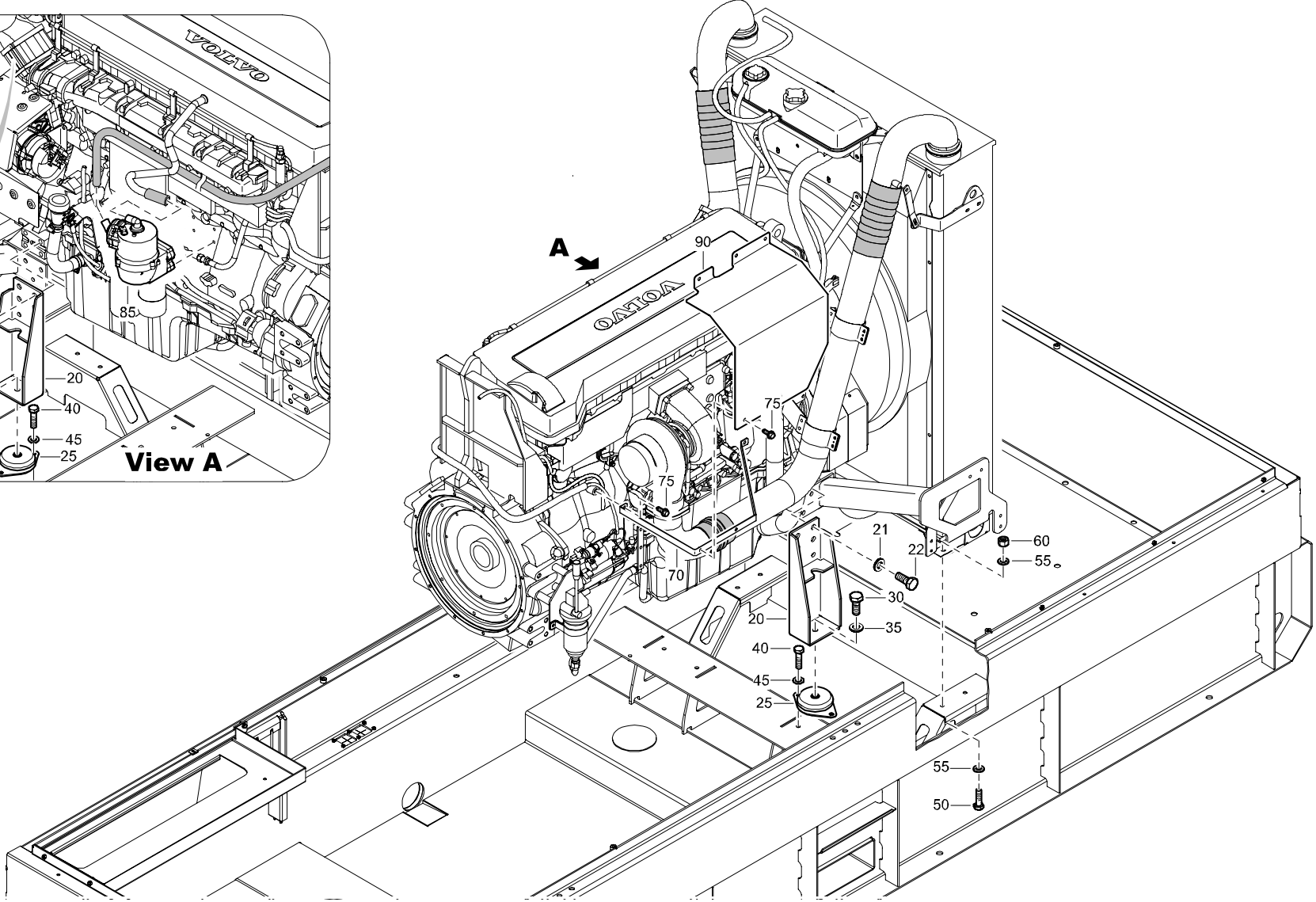
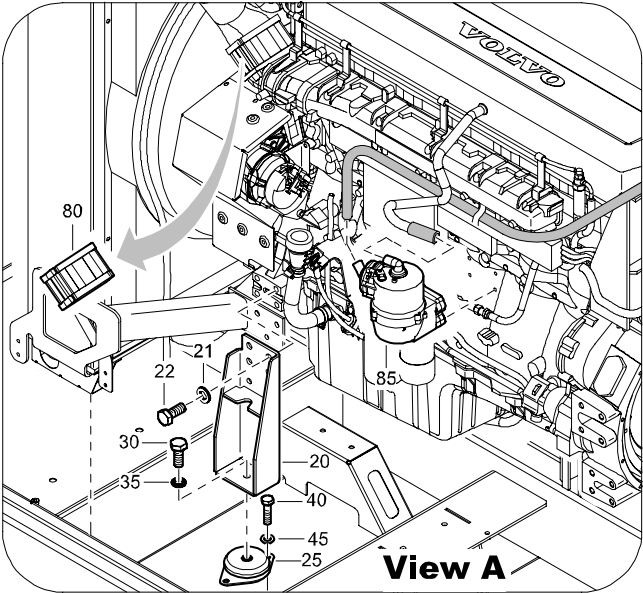

ENGINE AND ACCESSORIES - STANDARD

REF	PART NUMBER	DESIGNATION	QTY	REF	PART NUMBER	DESIGNATION	QTY	REF	PART NUMBER	DESIGNATION	QTY
20	1626 3933 01	SUPPORT ENGINE	2								
21	0333 5200 08	WASHER	8								
22	0147 1477 03	HEX. HEAD SCREW	8								
25	1619 5189 01	VIBR. DAMPER	2								
30	0147 1477 03	HEX. HEAD SCREW	2								
35	0333 5200 08	WASHER	2								
40	0147 1403 03	HEX. HEAD SCREW	4								
45	0301 2358 00	PLAIN WASHER	4								
50	0147 1403 03	HEX. HEAD SCREW	4								
55	0301 2358 00	PLAIN WASHER	8								
60	0266 2112 00	HEXAGON NUT	4								
70	1626 4422 00	BRACKET	1								
75	1619 2766 00	HEX. HEAD SCREW	4								
80	1626 4388 00	HEATER	1								
85	1626 4389 00	SEPARATOR	1								
90	1626 4157 00	SHIELD	1								

MARKINGS - STANDARD

REF	PART NUMBER	DESIGNATION	QTY	REF	PART NUMBER	DESIGNATION	QTY	REF	PART NUMBER	DESIGNATION	QTY
20	1079 9901 87	LABEL	1								
25	0690 1101 47	HOUSE MARK WHITE	2								
30	1626 3847 00	LABEL	2								
35	1079 9921 03	INFORMATION LABEL	1								
40	0690 1150 01	HOUSE MARK	1								
45	1604 3317 04	LABEL NOISE	1								
50	1079 9903 61	LABEL	3								
55	1079 9902 63	WARNING LABEL	1								
65	1604 7907 02	LABEL	1								
70	1079 9926 56	LABEL 3-WAY VALVE	1								
75	1088 1001 02	WARNING MARK	1								
80	1079 9929 86	LABEL	1								

TERMINAL BOARD - STANDARD

REF	PART NUMBER	DESIGNATION	QTY
20	1900 1036 70	TERMINAL BOARD	1
•A10	1626 2827 01	ISOLATOR	1
•A20	1626 2828 00	TERMINAL	5
•A30	1626 3666 00	BRACKET	10
•A40	1626 2821 00	ISOLATOR	4
•A50	1626 2822 00	BRACKET	4
•A60	1626 2823 00	PLATE	4
•A70	1089 0651 05	TERMINAL	5

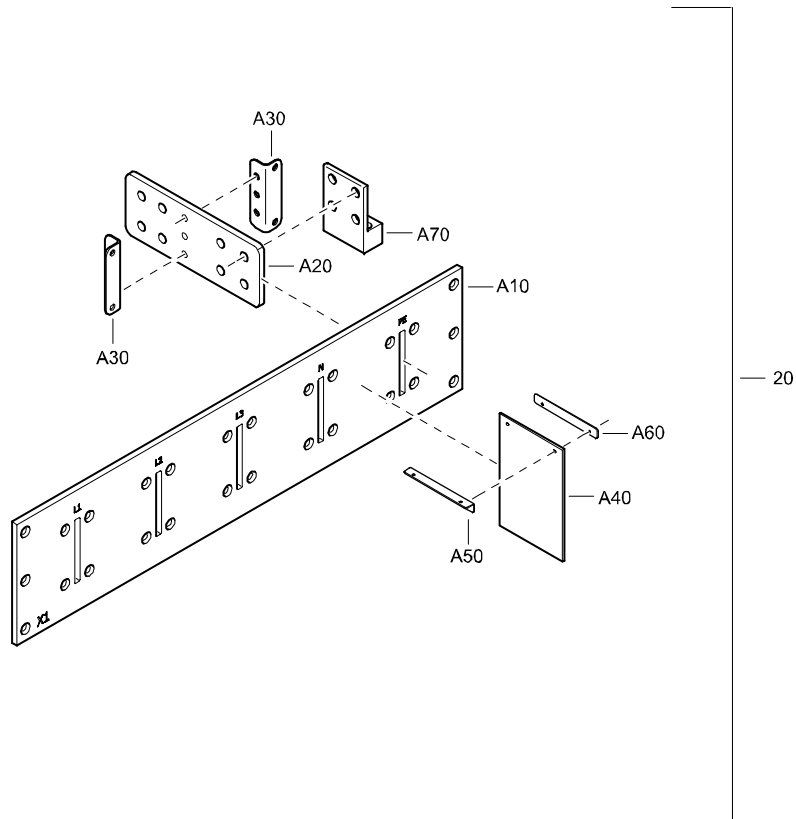

PLATES - FOR GENERATOR WITH NO SOCKET - 1PH - STANDARD

REF	PART NUMBER	DESIGNATION	QTY
20	1900 1036 72	NO SOCKETS	1
•A500	1626 0484 01	PLATE	1
•A502	1626 3676 01	PLATE	1

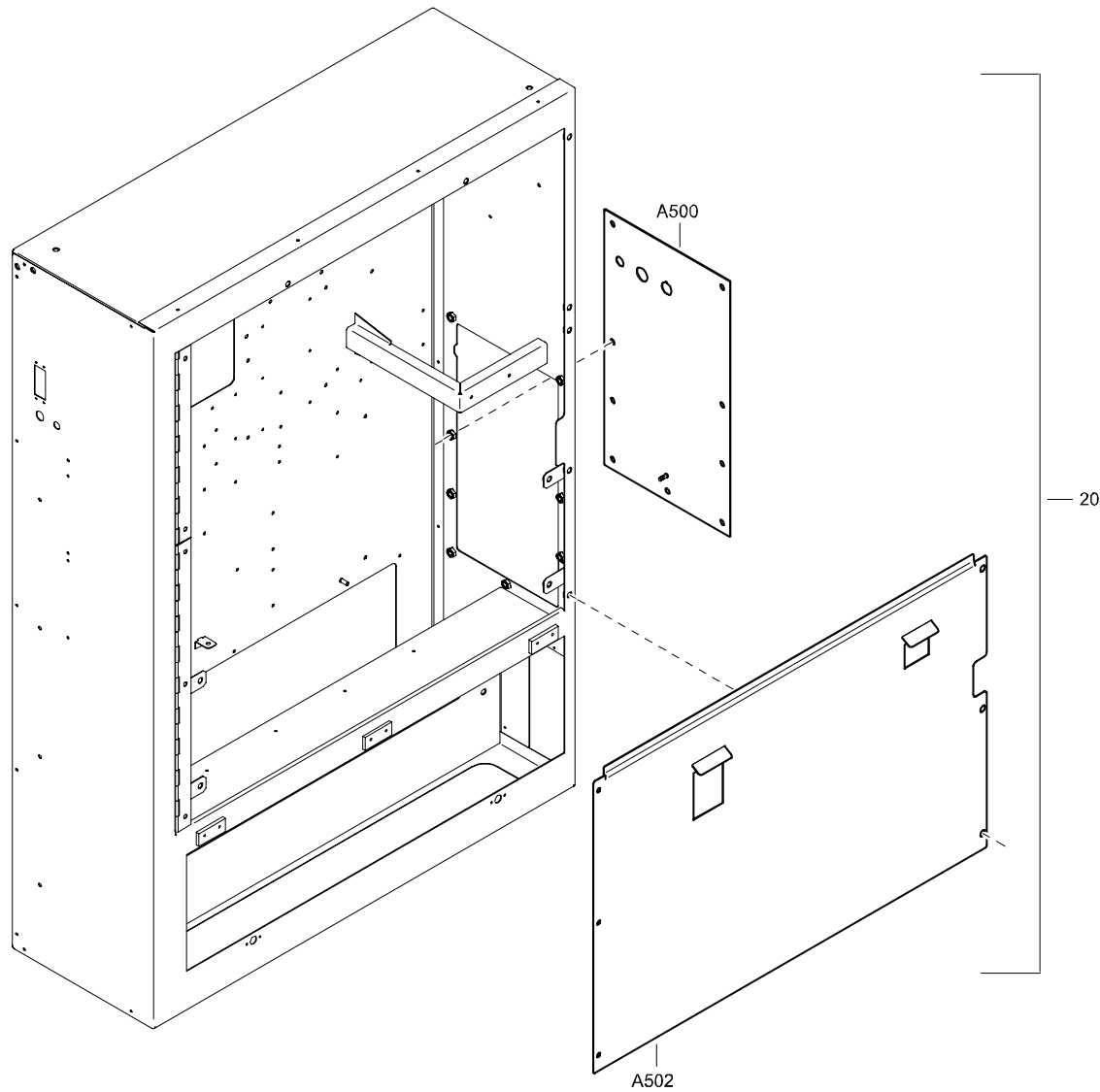

CUBICLE - 400V - STANDARD

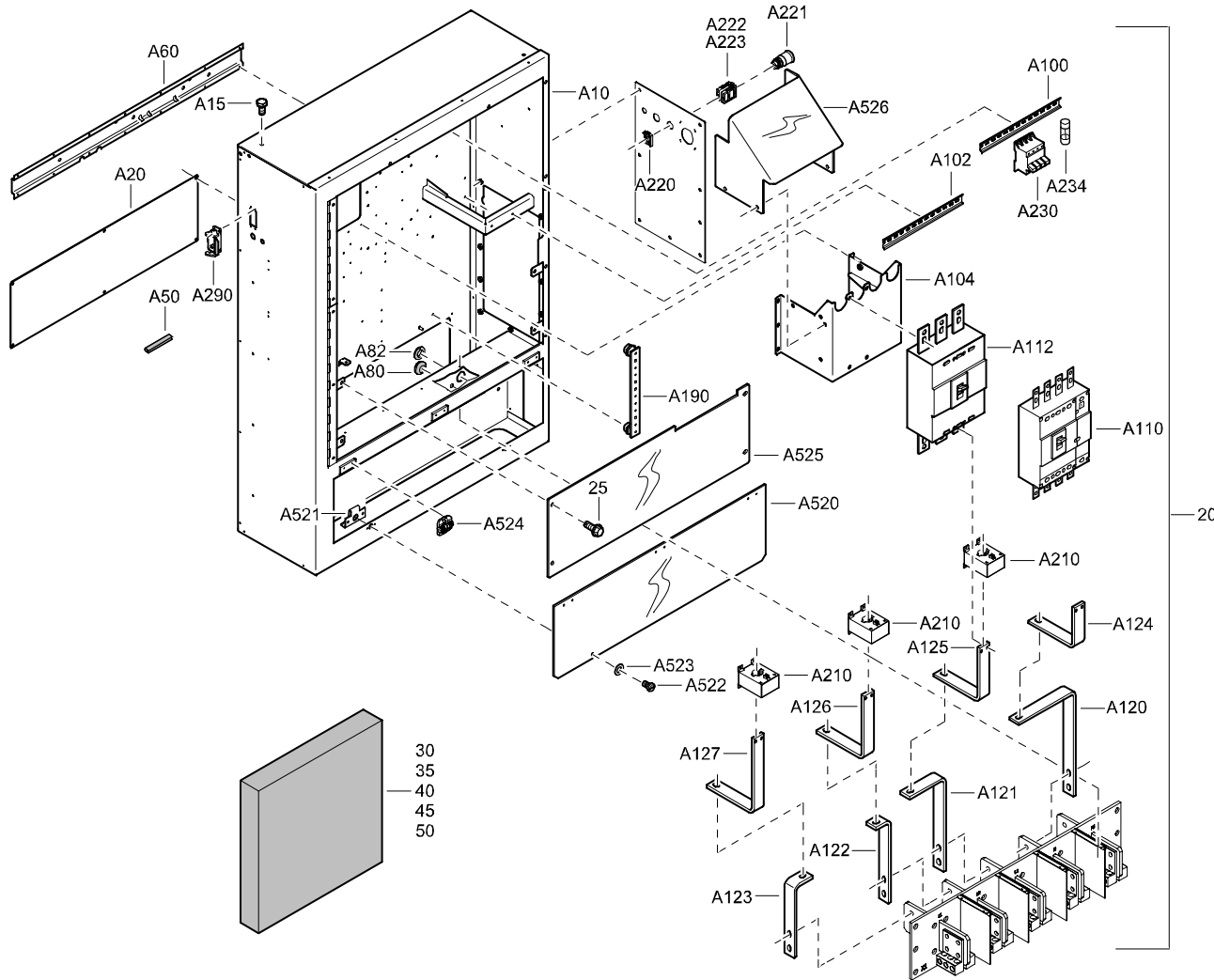

REF	PART NUMBER	DESIGNATION	QTY	
20	1900 1036 20	CUBICLE	1	
	•A10	1626 2678 01	BOX	1
	•A15	0147 1320 03	HEX. HEAD SCREW	2
	•A20	1626 2824 00	PLATE	1
	•A50	1503 1056 00	SEAL	AR
	•A60	1626 4301 00	PROFILE	1
	•A80	1088 0801 10	GROMMET	1
	•A82	1088 0801 31	GROMMET	1
	•A100	0993 7106 00	MOUNTING RAIL	AR
	•A102	0993 7106 00	MOUNTING RAIL	AR
	•A104	1626 3790 01	SUPPORT	1
	•A110	1089 9474 45	CIRCUIT BREAK.	1
	•A112	1089 9474 41	SHUNT TRIP	1
	•A120	1626 3512 00	TERMINAL	1
	•A121	1626 3513 00	TERMINAL	1
	•A122	1626 3514 00	TERMINAL	1
	•A123	1626 3515 00	TERMINAL	1
	•A124	1626 3679 00	TERMINAL	1
	•A125	1626 3680 00	TERMINAL	1
	•A126	1626 3681 00	TERMINAL	1
	•A127	1626 3682 00	TERMINAL	1
	•A190	1604 2285 00	EARTH RAIL ASS'Y	1
	•A210	1089 9357 73	TRANSFORMER	3
	•A220	1089 9622 04	SWITCH SELECTOR	1
	•A221	1089 9622 09	ACTUATOR	1
	•A222	1089 9622 08	CONTACT	1
	•A223	1089 9622 05	CONTACT	1
	•A230	1089 9356 11	FUSE HOLDER	1
	•A234	1089 9332 07	FUSE	3
	•A290	1088 0029 50	HOUSING	1
	•A520	1626 2825 01	SCREEN	1
	•A521	1615 6728 00	PLATE	2
	•A522	1615 7166 00	STUD	2
	•A523	1615 6727 00	WASHER	2
	•A524	1604 4146 00	HINGE	3
	•A525	1626 3830 01	COVER	1
	•A526	1626 4281 00	COVER	4
25	1619 2766 00	HEX. HEAD SCREW	4	
30	-	INSULATION	1	
35	-	SILENCING FOAM (30 mm)	1	
40	-	INSULATION	1	
45	-	SILENCING FOAM (30 mm)	1	
50	-	INSULATION	1	
50	-	SILENCING FOAM (30 mm)	1	
-	1079 0003 32	SILENCING FOAM 2000 mm x 1500 mm x 30 mm		

COOLANT HEATER - STANDARD

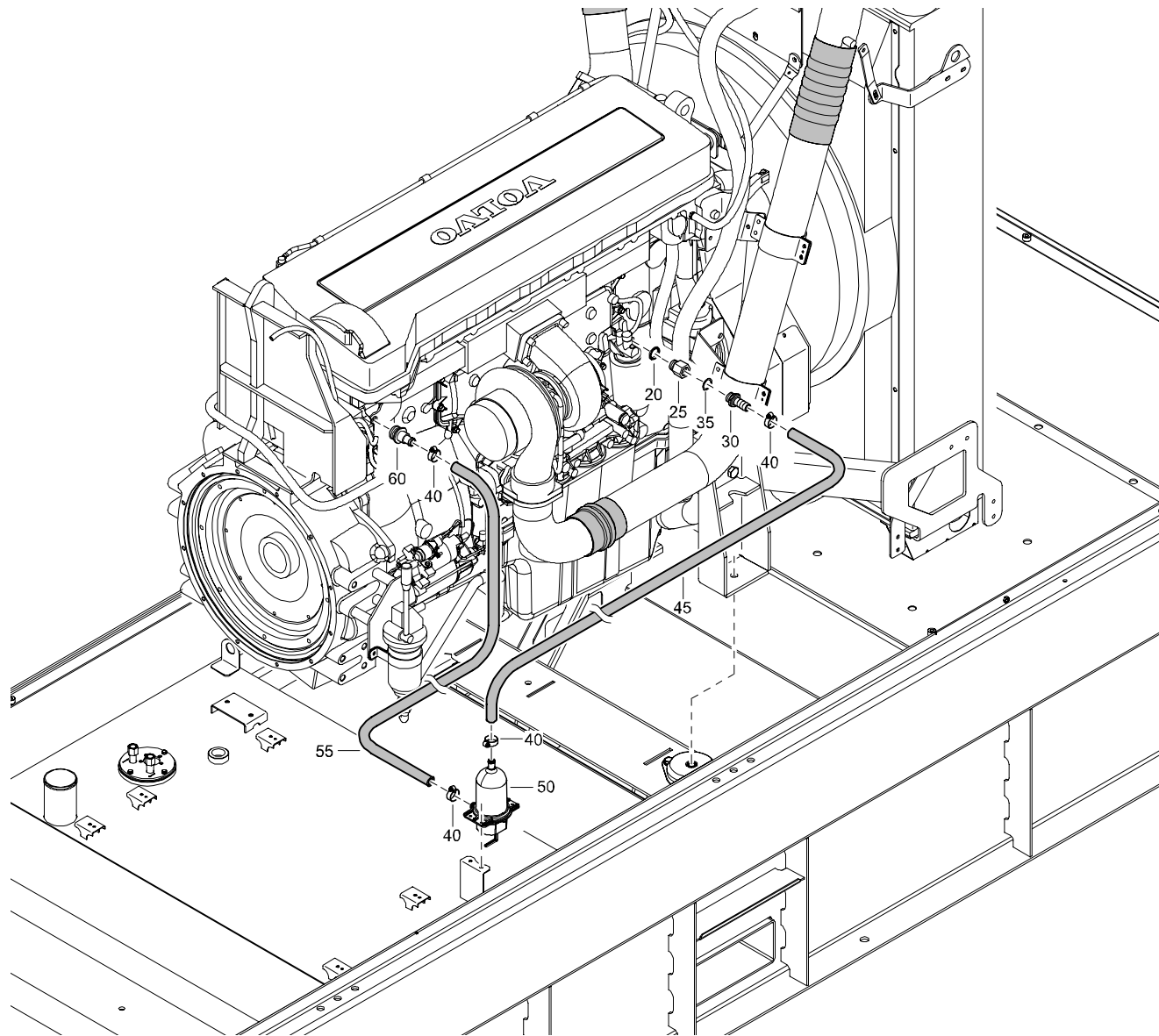

REF	PART NUMBER	DESIGNATION	QTY
20	0661 1033 00	SEALING WASHER	1
25	0571 0035 29	HEXAGON NIPPLE	1
30	0571 0020 20	HOSE NIPPLE	1
35	0653 1124 00	FLAT GASKET	1
40	0347 6106 00	HOSE CLAMP	4
45	0072 8403 16	HOSE	AR
50	1089 9403 05	COOLANT HEATER	1
55	0072 8403 16	HOSE	AR
60	1626 4070 00	NIPPLE	1

CUBICLE - 230V/400V - STANDARD

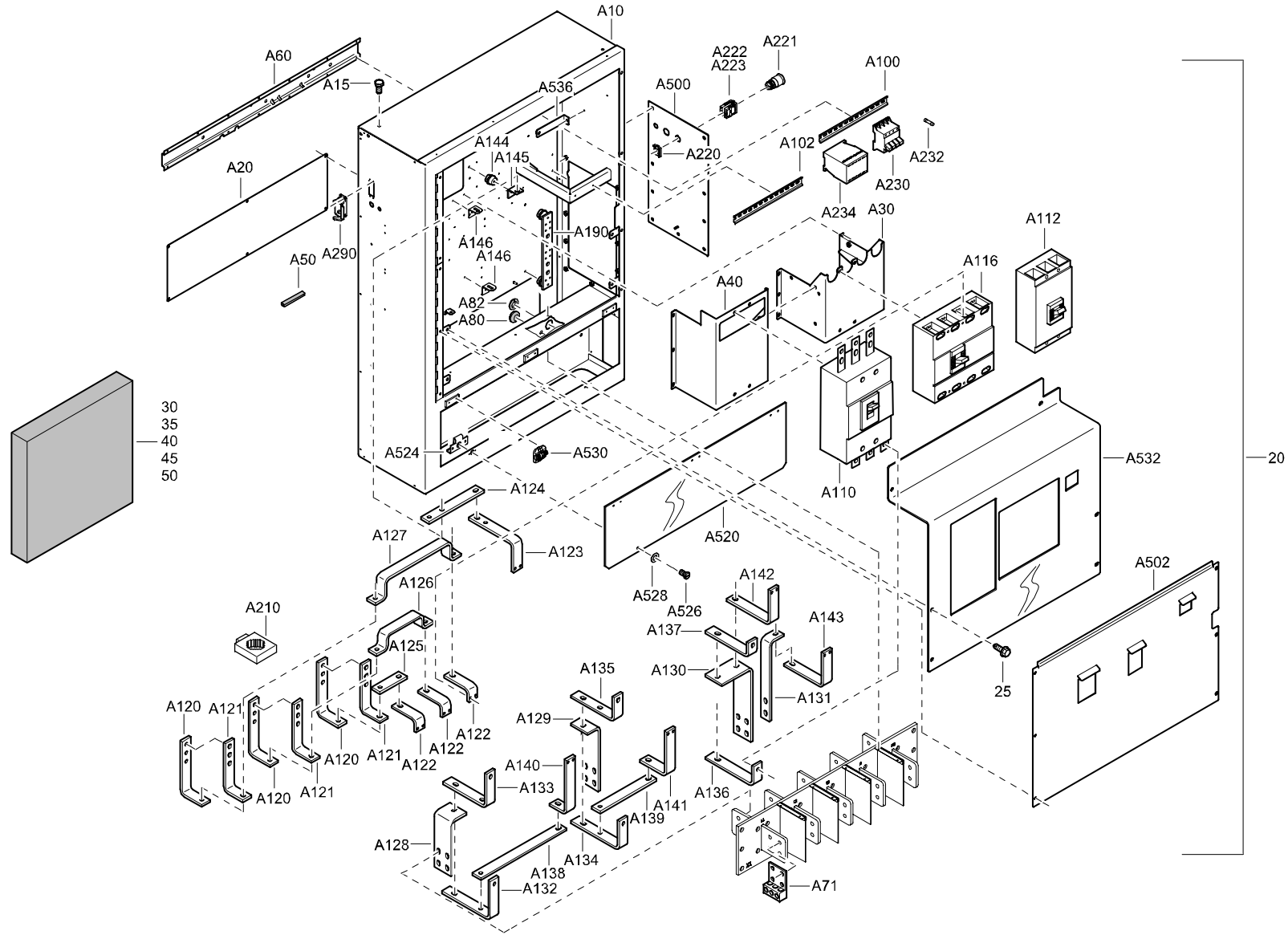

CUBICLE - STANDARD

REF	PART NUMBER	DESIGNATION	QTY	REF	PART NUMBER	DESIGNATION	QTY	REF	PART NUMBER	DESIGNATION	QTY
20	1900 1036 21	CUBICLE DUAL VOLTAGE	1	•A146	1626 3952 00	BRACKET	2				
•A10	1626 2678 01	BOX	1	•A190	1626 4123 00	ASSEMBLY	1				
•A15	0147 1320 03	HEX. HEAD SCREW	2	•A210	1089 9652 01	TRANSDUCER CUR	3				
•A20	1626 2824 00	PLATE	1	•A220	1089 9622 04	SWITCH SELECTOR	1				
•A30	1626 3790 01	SUPPORT	1	•A221	1089 9622 09	ACTUATOR	1				
•A40	1626 3792 00	SUPPORT	1	•A222	1089 9622 08	CONTACT	1				
•A50	1503 1056 00	SEAL	AR	•A223	1089 9622 05	CONTACT	1				
•A60	1626 4301 00	PROFILE	1	•A230	1089 9356 11	FUSE HOLDER	1				
•A71	1089 0651 05	TERMINAL	5	•A232	1089 9332 01	FUSE	3				
•A80	1088 0801 10	GROMMET	1	•A234	1626 1974 00	TRANSFORMER	1				
•A82	1088 0801 31	GROMMET	1	•A290	1088 0029 50	HOUSING	1				
•A100	0993 7106 00	MOUNTING RAIL	AR	•A500	1626 0484 01	PLATE	1				
•A102	0993 7106 00	MOUNTING RAIL	AR	•A502	1626 3675 01	PLATE	1				
•A110	1089 9474 46	CIRCUIT BREAK.	1	•A520	1626 2825 01	SCREEN	1				
•A112	1089 9474 23	CIRCUIT BREAK.	1	•A524	1615 6728 00	PLATE	2				
•A116	1089 9474 48	CIRCUIT BREAK.	1	•A526	1615 7166 00	STUD	2				
•A120	1626 3724 00	BAR	3	•A528	1615 6727 00	WASHER	2				
•A121	1626 3735 00	BAR	3	•A530	1604 4146 00	HINGE	3				
•A122	1626 3732 00	BAR	3	•A532	1626 3963 01	COVER	1				
•A123	1626 3929 00	BAR	1	•A536	1626 4117 00	BRACKET	2				
•A124	1626 3930 00	BAR	1	25	1619 2766 00	HEX. HEAD SCREW	4				
•A125	1626 3731 00	BAR	1	30	-	INSULATION	1				
•A126	1626 3733 00	BAR	1			SILENCING FOAM (30 mm)					
•A127	1626 3734 00	BAR	1	35	-	INSULATION	1				
•A128	1626 3714 00	BAR	1			SILENCING FOAM (30 mm)					
•A129	1626 3715 00	BAR	1	40	-	INSULATION	1				
•A130	1626 3716 00	BAR	1			SILENCING FOAM (30 mm)					
•A131	1626 3717 00	BAR	1	45	-	INSULATION	1				
•A132	1626 3718 00	BAR	1			SILENCING FOAM (30 mm)					
•A133	1626 3751 00	BAR	1	50	-	INSULATION	1				
•A134	1626 3719 00	BAR	1			SILENCING FOAM (30 mm)					
•A135	1626 3752 00	BAR	1								
•A136	1626 3720 00	BAR	1								
•A137	1626 3753 00	BAR	1								
•A138	1626 3726 00	BAR	1								
•A139	1626 3725 00	BAR	1	-	1079 0003 32	SILENCING FOAM					
•A140	1626 3721 00	BAR	1			2000 mm x 1500 mm x 30 mm					
•A141	1626 3722 00	BAR	1								
•A142	1626 3723 00	BAR	1								
•A143	1626 3679 00	TERMINAL	1								
•A144	1089 9385 13	ISOLATOR	1								
•A145	2250 3428 00	BRACKET	1								

BATTERY CHARGER + COOLANT HEATER

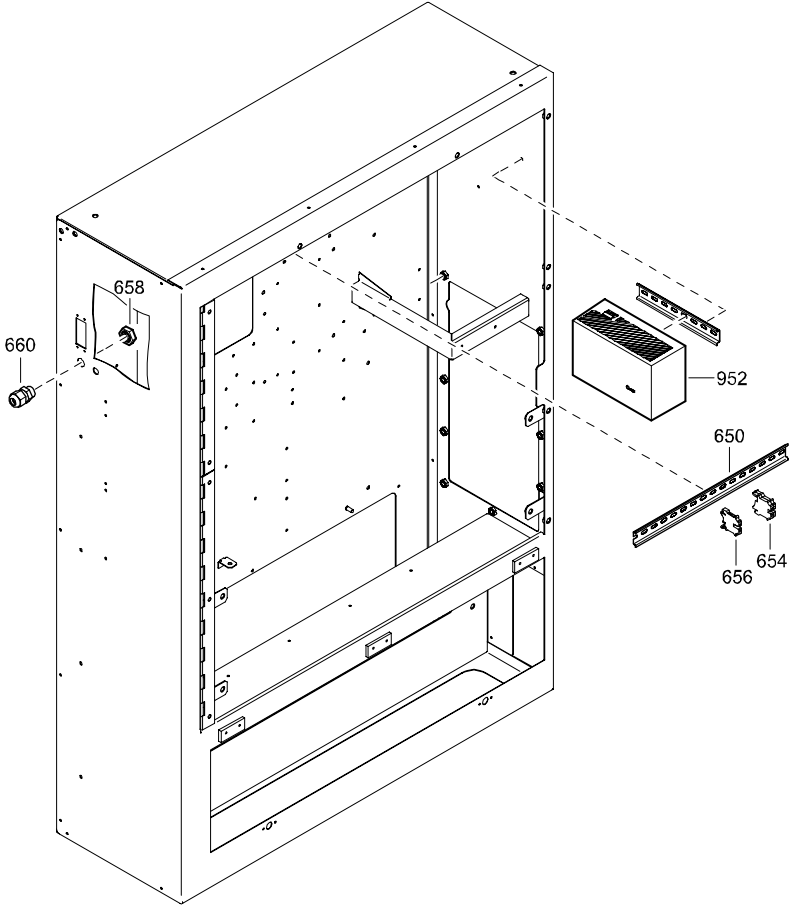

REF	PART NUMBER	DESIGNATION	QTY
650	0993 7106 00	MOUNTING RAIL	AR
654	1089 0577 12	TERMINAL	2
656	1089 0577 29	TERMINAL	1
658	0697 9809 20	LOCK NUT	1
660	0698 5140 71	CABLE GLAND	1
952	1089 0697 33	POWER SUPPLY	1

BEAM - STANDARD

REF	PART NUMBER	DESIGNATION	QTY
-	1626 2124 81	BEAM	(From page 40)
•5	1626 2124 01	BEAM	1
•10	1604 3428 00	HINGE	2
•15	0216 1324 03	HEX SOCK. SCREW	4

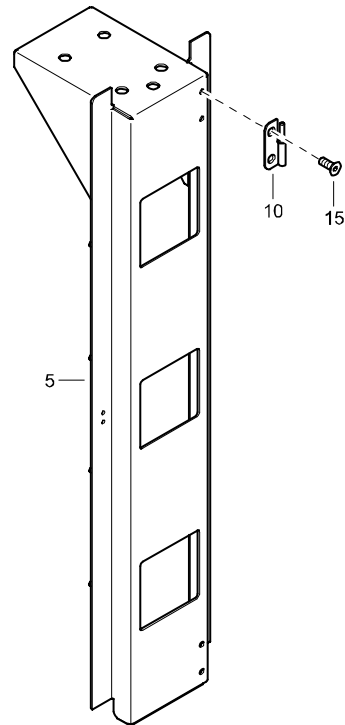

BEAM - STANDARD

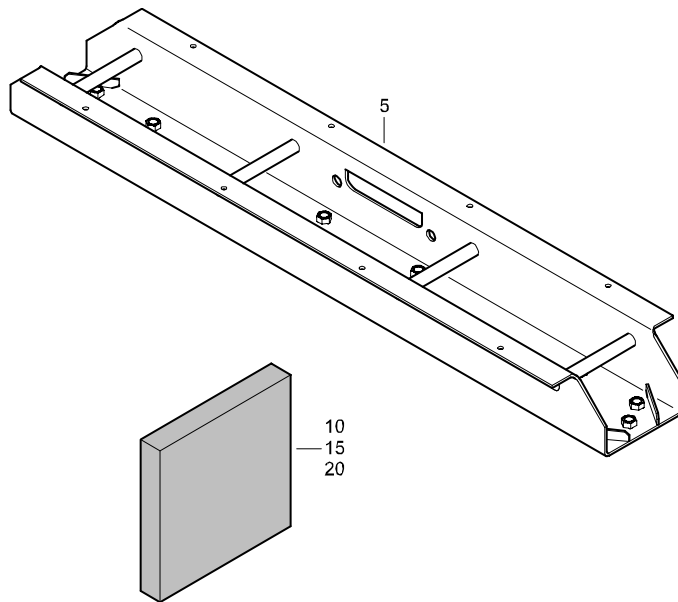

REF	PART NUMBER	DESIGNATION	QTY
-	1626 2125 81	BEAM	(From page 40)
•5	1626 2125 01	BEAM	1
•10	-	INSULATION SILENCING FOAM (50 mm)	1
•15	-	INSULATION SILENCING FOAM (50 mm)	1
•20	-	INSULATION SILENCING FOAM (50 mm)	1
-	1079 0003 33	SILENCING FOAM 2000 mm x 1500 mm x 50 mm	

BEAM - STANDARD

REF	PART NUMBER	DESIGNATION	QTY
-	1626 2126 81	BEAM	(From page 40)
•5	1626 2126 01	BEAM	1
•10	1626 3843 00	EYE	1
•15	0211 1964 99	SCREW	4
•20	0261 1090 19	NUT	4

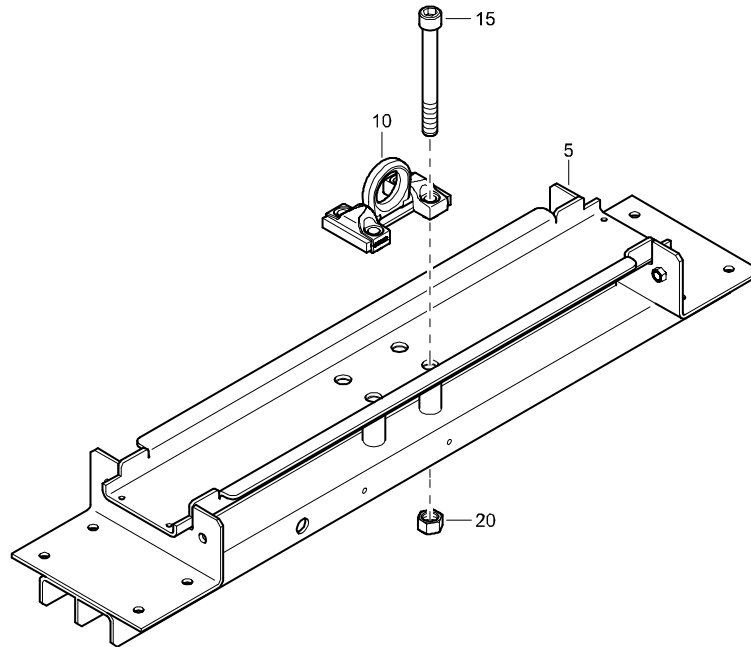

BEAM - STANDARD

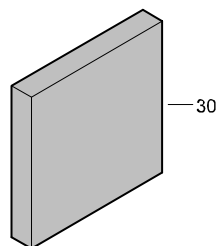
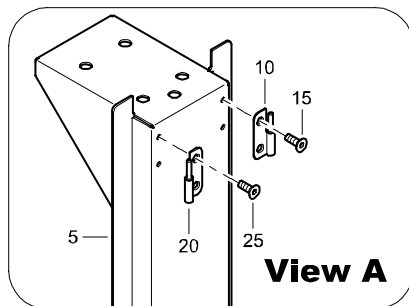
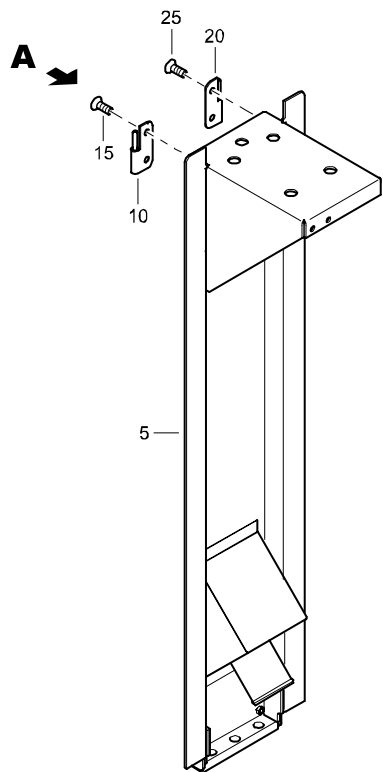

REF	PART NUMBER	DESIGNATION	QTY
-	1626 3156 81	BEAM	(From page 40)
•5	1626 3156 01	BEAM	1
•10	1604 3428 00	HINGE	2
•15	0216 1324 03	HEX SOCK. SCREW	4
•20	1604 3430 00	HINGE	2
•25	0216 1324 03	HEX SOCK. SCREW	4
•30	-	INSULATION SILENCING FOAM (50 mm)	1
-	1079 0003 33	SILENCING FOAM 2000 mm x 1500 mm x 50 mm	

CORNER - STANDARD

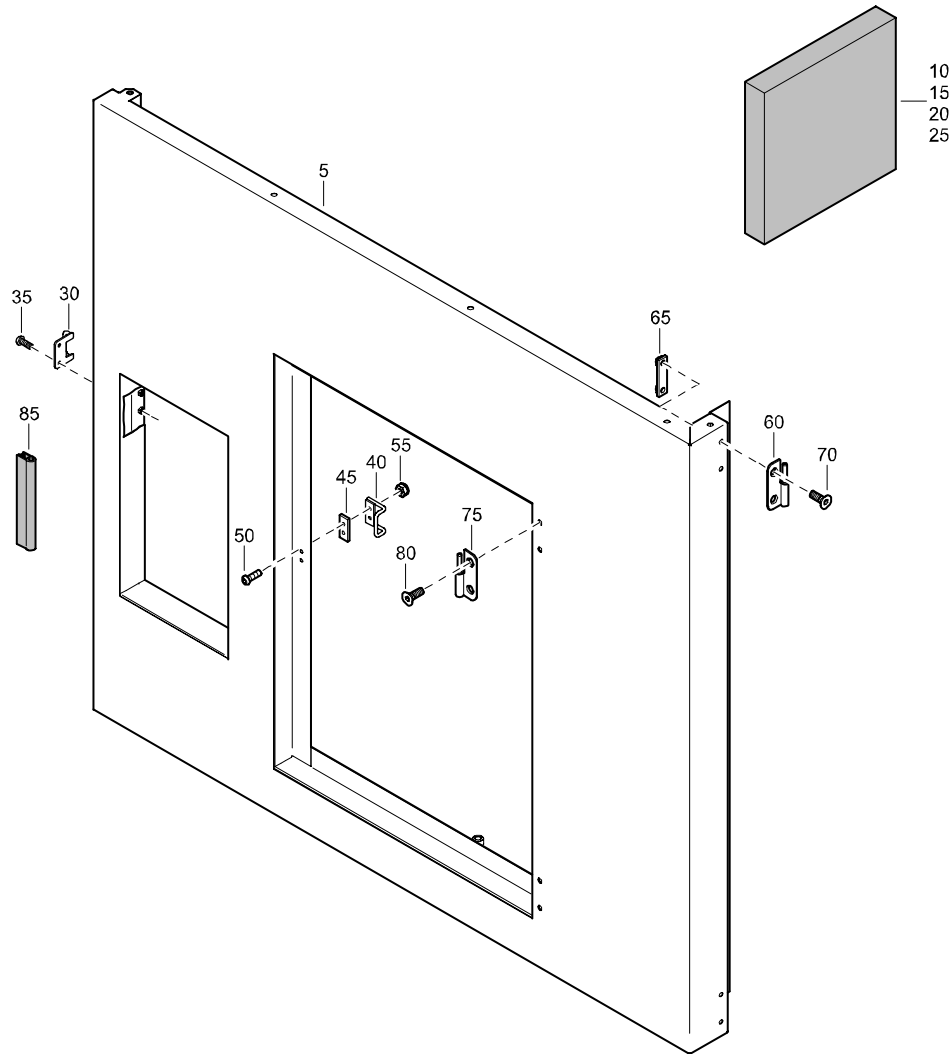

REF	PART NUMBER	DESIGNATION	QTY
-	1626 2131 81	CORNER (From page 40)	
•5	1626 2131 01	CORNER	1
•10	-	INSULATION SILENCING FOAM (50 mm)	1
•15	-	INSULATION SILENCING FOAM (50 mm)	1
•20	-	INSULATION SILENCING FOAM (50 mm)	1
•25	-	INSULATION SILENCING FOAM (50 mm)	1
•30	1626 4454 00	BRACKET	1
•35	3222 3112 92	BOLT	2
•40	1604 5031 00	BRACKET	1
•45	1626 2817 00	SPACER	1
•50	0215 0003 89	SCREW	2
•55	0291 1108 00	LOCKNUT	2
•60	1604 3428 00	HINGE	2
•65	1615 5684 00	BRACKET	2
•70	0216 1324 03	HEX SOCK. SCREW	4
•75	1604 3430 00	HINGE	2
•80	0216 1324 03	HEX SOCK. SCREW	4
•85	1202 6584 00	SEAL	AR
-	1079 0003 33	SILENCING FOAM 2000 mm x 1500 mm x 50 mm	

CORNER - STANDARD

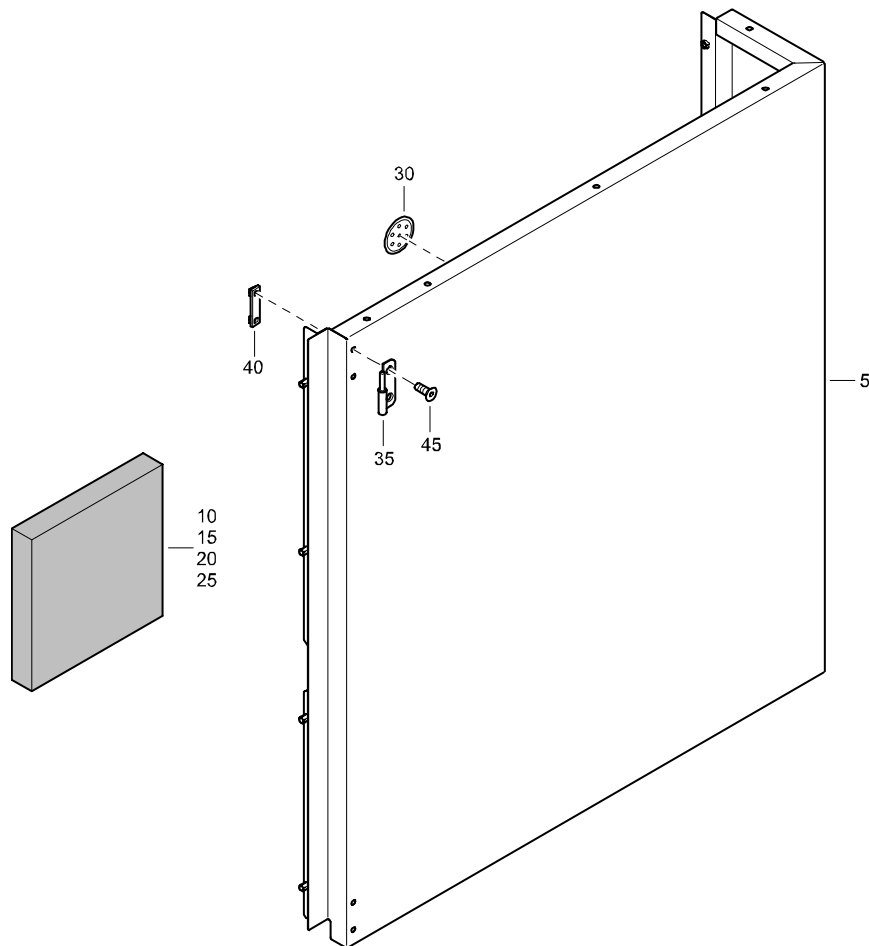

REF	PART NUMBER	DESIGNATION	QTY
-	1626 2139 81	CORNER	(From page 40)
•5	1626 2139 01	CORNER	1
•10	-	INSULATION SILENCING FOAM (50 mm)	2
•15	-	INSULATION SILENCING FOAM (50 mm)	1
•20	-	INSULATION SILENCING FOAM (50 mm)	1
•25	-	INSULATION SILENCING FOAM (50 mm)	1
•30	1615 7884 00	CLIP	16
•35	1604 3430 00	HINGE	2
•40	1615 5684 00	BRACKET	2
•45	0216 1324 03	HEX SOCK. SCREW	4
-	1079 0003 33	SILENCING FOAM 2000 mm x 1500 mm x 50 mm	

CORNER - STANDARD

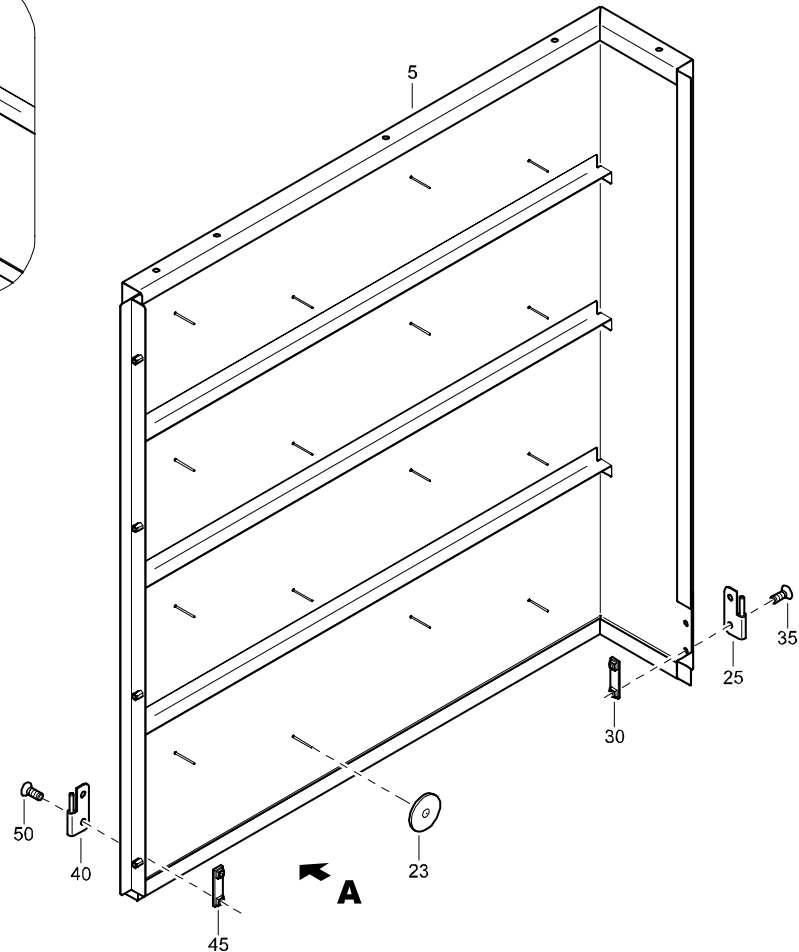
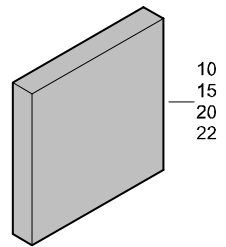
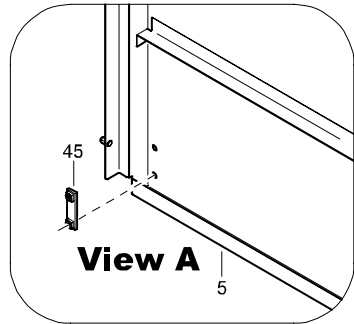

REF	PART NUMBER	DESIGNATION	QTY
-	1626 3575 81	CORNER (From page 40)	
•5	1626 3575 01	CORNER	1
•10	-	INSULATION SILENCING FOAM (50 mm)	2
•15	-	INSULATION SILENCING FOAM (50 mm)	1
•20	-	INSULATION SILENCING FOAM (50 mm)	1
•22	-	INSULATION SILENCING FOAM (50 mm)	1
•23	1615 7884 00	CLIP	16
•25	1604 3430 00	HINGE	2
•30	1615 5684 00	BRACKET	2
•35	0216 1324 03	HEX SOCK. SCREW	4
•40	1604 3428 00	HINGE	2
•45	1615 5684 00	BRACKET	2
•50	0216 1324 03	HEX SOCK. SCREW	4
-	1079 0003 33	SILENCING FOAM 2000 mm x 1500 mm x 50 mm	

DOOR - STANDARD

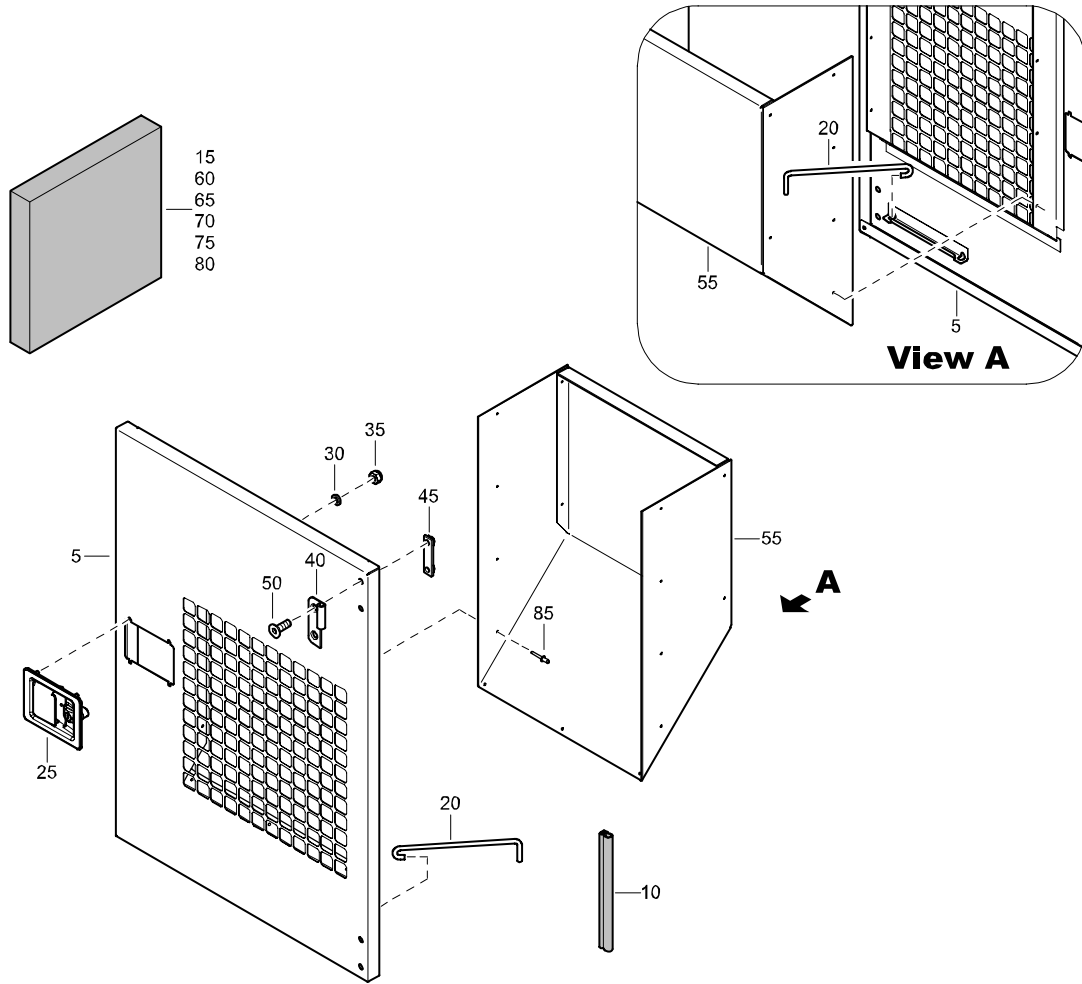

REF	PART NUMBER	DESIGNATION	QTY
-	1626 2121 81	DOOR	(From page 40)
•5	1626 2121 01	DOOR	1
•10	1604 4317 00	SEAL	AR
•15	-	INSULATION	
		SILENCING FOAM (50 mm)	1
•20	1626 3797 01	RETAINER	1
•25	1615 6967 03	HANDLE	1
•30	0301 2321 00	PLAIN WASHER	4
•35	0291 1108 00	LOCKNUT	4
•40	1604 3431 00	HINGE	2
•45	1615 5684 00	BRACKET	2
•50	0216 1324 03	HEX SOCK. SCREW	4
•55	1626 4411 00	BOX	1
•60	-	INSULATION	
		SILENCING FOAM (30 mm)	1
•65	-	INSULATION	
		SILENCING FOAM (30 mm)	1
•70	-	INSULATION	
		SILENCING FOAM (50 mm)	1
•75	-	INSULATION	
		SILENCING FOAM (30 mm)	1
•80	-	INSULATION	
		SILENCING FOAM (30 mm)	1
•85	0129 3172 01	RIVET	15
-	1079 0003 32	SILENCING FOAM 2000 mm x 1500 mm x 30 mm	
-	1079 0003 33	SILENCING FOAM 2000 mm x 1500 mm x 50 mm	

DOOR - STANDARD

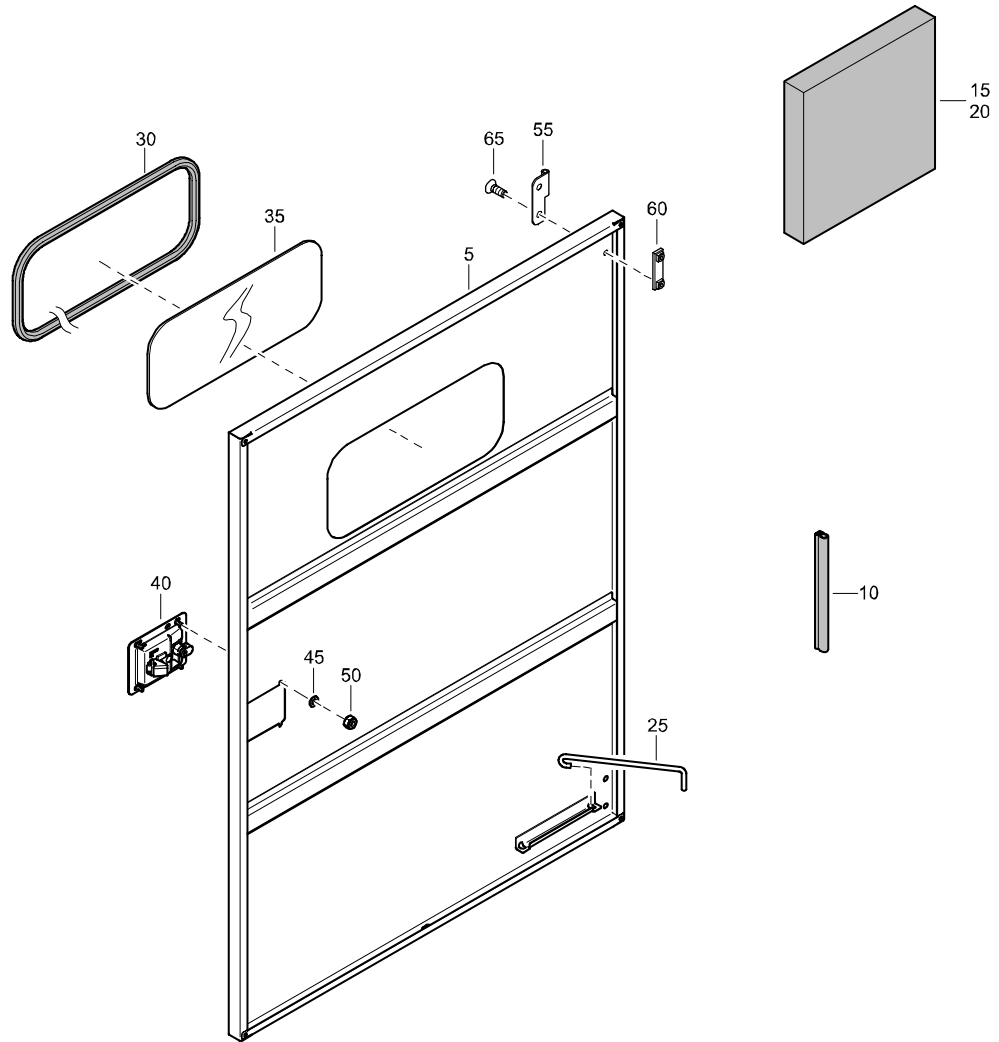

REF	PART NUMBER	DESIGNATION	QTY
-	1626 2134 81	DOOR (From page 40)	
•5	1626 2134 01	DOOR CUBICLE	1
•10	1604 4317 00	SEAL	AR
•15	-	INSULATION	
		SILENCING FOAM (30 mm)	1
•20	-	INSULATION	
		SILENCING FOAM (30 mm)	1
•25	1626 3797 01	RETAINER	1
•30	1604 4541 00	SEAL	AR
•35	1604 4922 00	WINDOW	1
•40	1615 6967 03	HANDLE	1
•45	0301 2321 00	PLAIN WASHER	4
•50	0291 1108 00	LOCKNUT	4
•55	1604 3429 00	HINGE	2
•60	1615 5684 00	BRACKET	2
•65	0216 1324 03	HEX SOCK. SCREW	4
-	1079 0003 32	SILENCING FOAM 2000 mm x 1500 mm x 30 mm	

DOOR - STANDARD

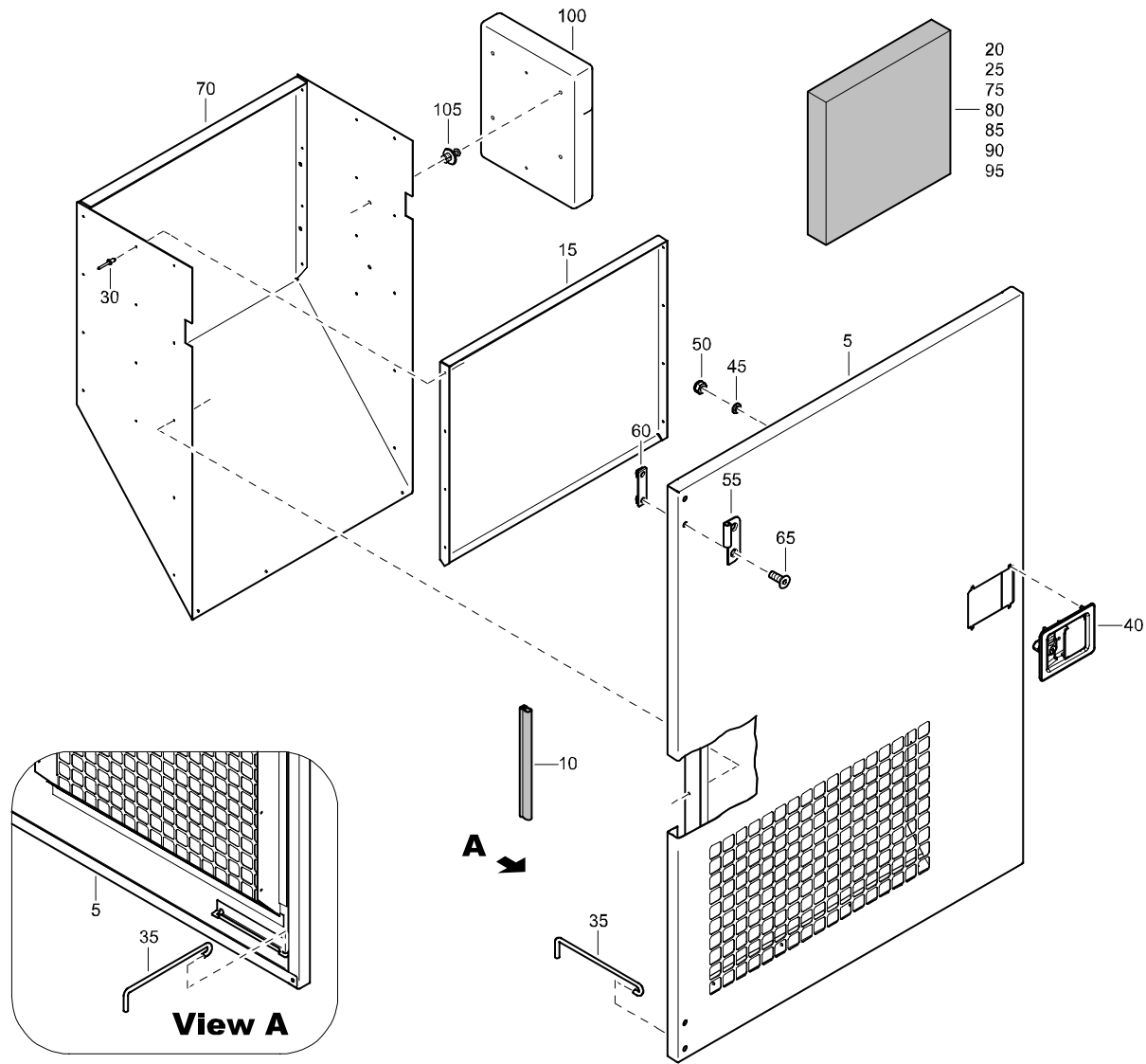

REF	PART NUMBER	DESIGNATION	QTY
-	1626 2136 81	DOOR	(From page 40)
•5	1626 2136 01	DOOR	1
•10	1604 4317 00	SEAL	AR
•15	1626 2654 01	PLATE	1
•20	-	INSULATION	
		SILENCING FOAM (50 mm)	1
•25	-	INSULATION	
		SILENCING FOAM (30 mm)	3
•30	0129 3172 01	RIVET	27
•35	1626 3797 01	RETAINER	1
•40	1615 6967 03	HANDLE	1
•45	0301 2321 00	PLAIN WASHER	4
•50	0291 1108 00	LOCKNUT	4
•55	1604 3429 00	HINGE	2
•60	1615 5684 00	BRACKET	2
•65	0216 1324 03	HEX SOCK. SCREW	4
•70	1626 4427 00	BOX	1
•75	-	INSULATION	
		SILENCING FOAM (30 mm)	1
•80	-	INSULATION	
		SILENCING FOAM (50 mm)	1
•85	-	INSULATION	
		SILENCING FOAM (30 mm)	1
•90	-	INSULATION	
		SILENCING FOAM (30 mm)	1
•95	-	INSULATION	
		SILENCING FOAM (50 mm)	1
•100	1604 2206 00	HOLDER (DOCUMENT)	1
•105	1615 5556 00	RIVET	4
-	1079 0003 32	SILENCING FOAM 2000 mm x 1500 mm x 30 mm	
-	1079 0003 33	SILENCING FOAM 2000 mm x 1500 mm x 50 mm	

DOOR - STANDARD

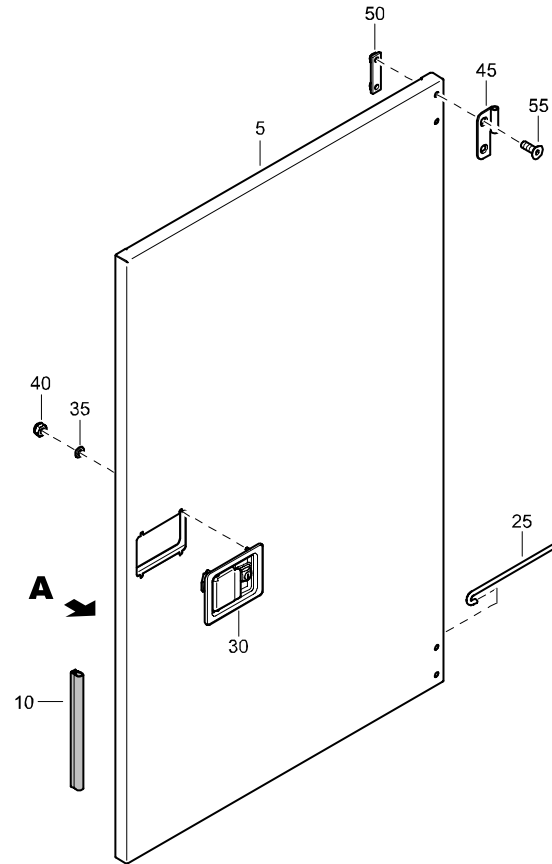
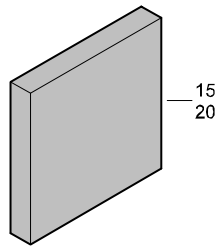
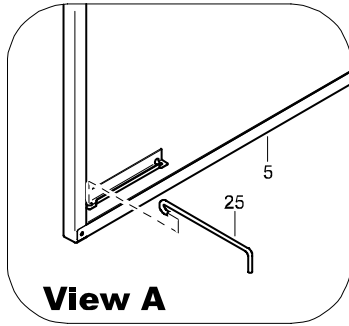

REF	PART NUMBER	DESIGNATION	QTY
-	1626 2655 81	DOOR (From page 40)	
•5	1626 2655 01	DOOR	1
•10	1604 4317 00	SEAL	AR
•15	-	INSULATION	
		SILENCING FOAM (50 mm)	1
•20	-	INSULATION	
		SILENCING FOAM (50 mm)	1
•25	1626 3797 01	RETAINER	1
•30	1615 6967 03	HANDLE	1
•35	0301 2321 00	PLAIN WASHER	4
•40	0291 1108 00	LOCKNUT	4
•45	1604 3431 00	HINGE	2
•50	1615 5684 00	BRACKET	2
•55	0216 1324 03	HEX SOCK. SCREW	4
-	1079 0003 33	SILENCING FOAM 2000 mm x 1500 mm x 50 mm	

DOOR - STANDARD

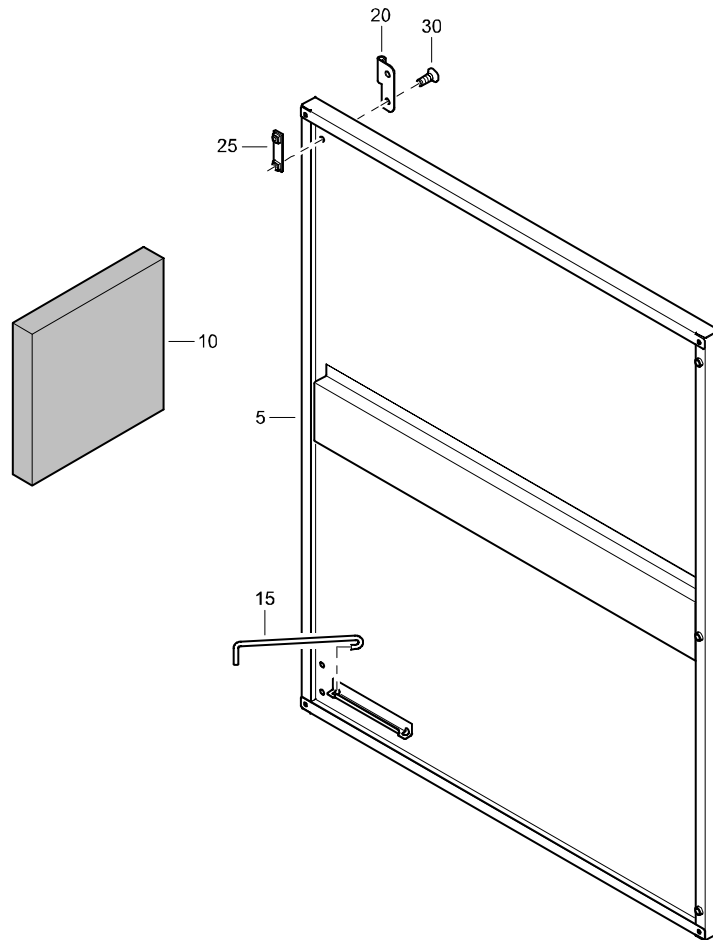

REF	PART NUMBER	DESIGNATION	QTY
-	1626 2659 81	DOOR	(From page 40)
•5	1626 2659 01	PANEL	1
•10	-	INSULATION SILENCING FOAM (50 mm)	2
•15	1626 3797 01	RETAINER	1
•20	1604 3431 00	HINGE	2
•25	1615 5684 00	BRACKET	2
•30	0216 1324 03	HEX SOCK. SCREW	4
-	1079 0003 33	SILENCING FOAM 2000 mm x 1500 mm x 50 mm	

DOOR - STANDARD

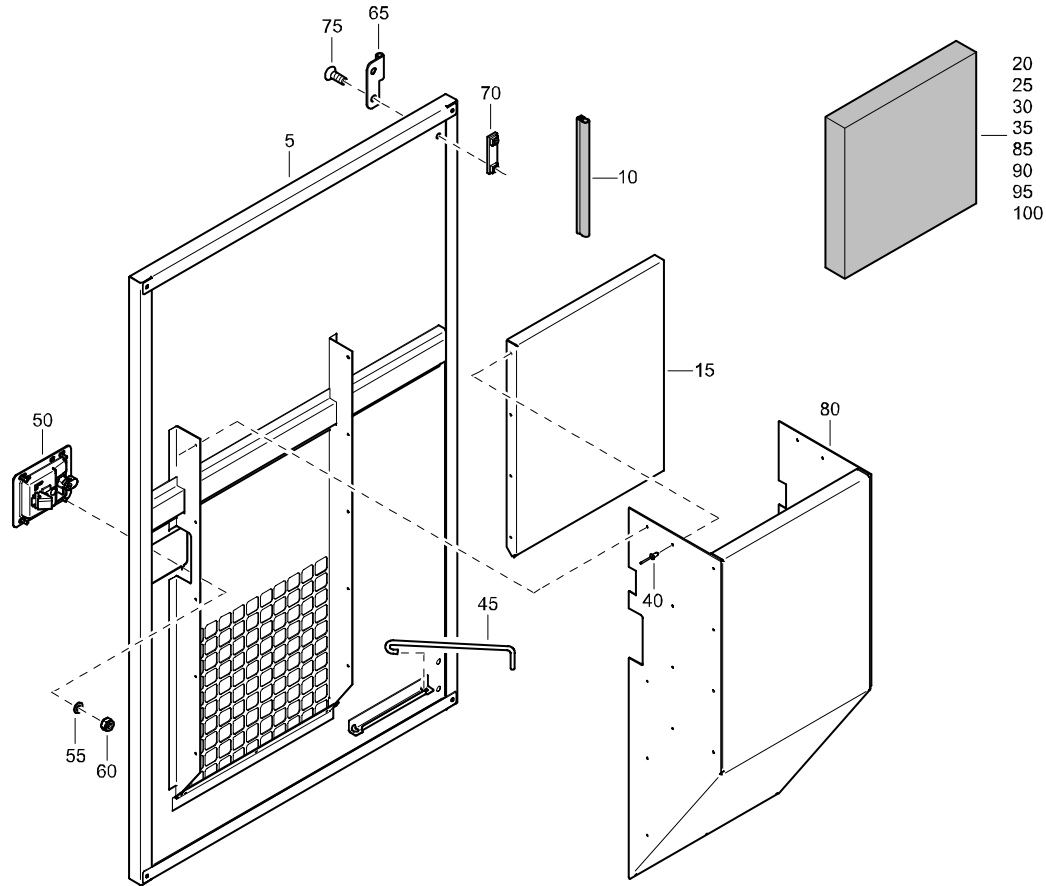

REF	PART NUMBER	DESIGNATION	QTY
-	1626 3552 81	DOOR (From page 40)	
•5	1626 3552 01	DOOR	1
•10	1604 4317 00	SEAL	AR
•15	1626 3940 01	PLATE	1
•20	-	INSULATION	1
		SILENCING FOAM (50 mm)	
•25	-	INSULATION	3
		SILENCING FOAM (30 mm)	
•30	-	INSULATION	1
		SILENCING FOAM (30 mm)	
•35	-	INSULATION	1
		SILENCING FOAM (30 mm)	
•40	0129 3172 01	RIVET	29
•45	1626 3797 01	RETAINER	1
•50	1615 6967 03	HANDLE	1
•55	0301 2321 00	PLAIN WASHER	4
•60	0291 1108 00	LOCKNUT	4
•65	1604 3429 00	HINGE	2
•70	1615 5684 00	BRACKET	2
•75	0216 1324 03	HEX SOCK. SCREW	4
•80	1626 4412 00	BOX	1
•85	-	INSULATION	1
		SILENCING FOAM (30 mm)	
•90	-	INSULATION	1
		SILENCING FOAM (50 mm)	
•95	-	INSULATION	1
		SILENCING FOAM (50 mm)	
•100	-	INSULATION	1
		SILENCING FOAM (50 mm)	
-	1079 0003 32	SILENCING FOAM 2000 mm x 1500 mm x 30 mm	
-	1079 0003 33	SILENCING FOAM 2000 mm x 1500 mm x 50 mm	

DOOR - STANDARD

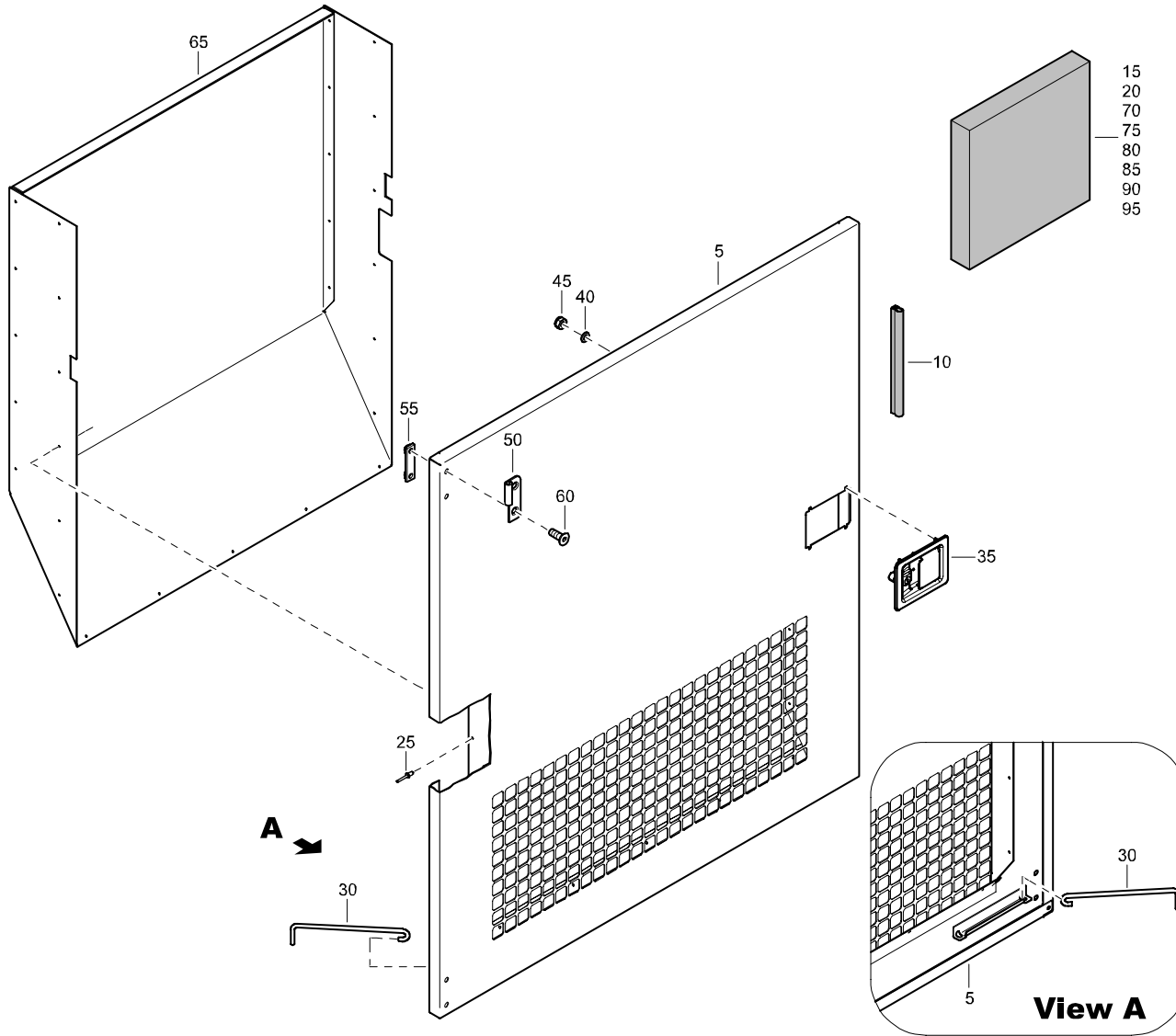

REF	PART NUMBER	DESIGNATION	QTY
-	1626 3553 81	DOOR	(From page 40)
•5	1626 3553 01	DOOR	1
•10	1604 4317 00	SEAL	AR
•15	-	INSULATION	1
		SILENCING FOAM (50 mm)	
•20	-	INSULATION	1
		SILENCING FOAM (30 mm)	
•25	0129 3172 01	RIVET	30
•30	1626 3797 01	RETAINER	1
•35	1615 6967 03	HANDLE	1
•40	0301 2321 00	PLAIN WASHER	4
•45	0291 1108 00	LOCKNUT	4
•50	1604 3429 00	HINGE	2
•55	1615 5684 00	BRACKET	2
•60	0216 1324 03	HEX SOCK. SCREW	4
•65	1626 4255 00	BOX	1
•70	-	INSULATION	1
		SILENCING FOAM (30 mm)	
•75	-	INSULATION	1
		SILENCING FOAM (50 mm)	
•80	-	INSULATION	1
		SILENCING FOAM (50 mm)	
•85	-	INSULATION	1
		SILENCING FOAM (30 mm)	
•90	-	INSULATION	1
		SILENCING FOAM (30 mm)	
•95	-	INSULATION	1
		SILENCING FOAM (50 mm)	
-	1079 0003 32	SILENCING FOAM 2000 mm x 1500 mm x 30 mm	
-	1079 0003 33	SILENCING FOAM 2000 mm x 1500 mm x 50 mm	

DOOR - STANDARD

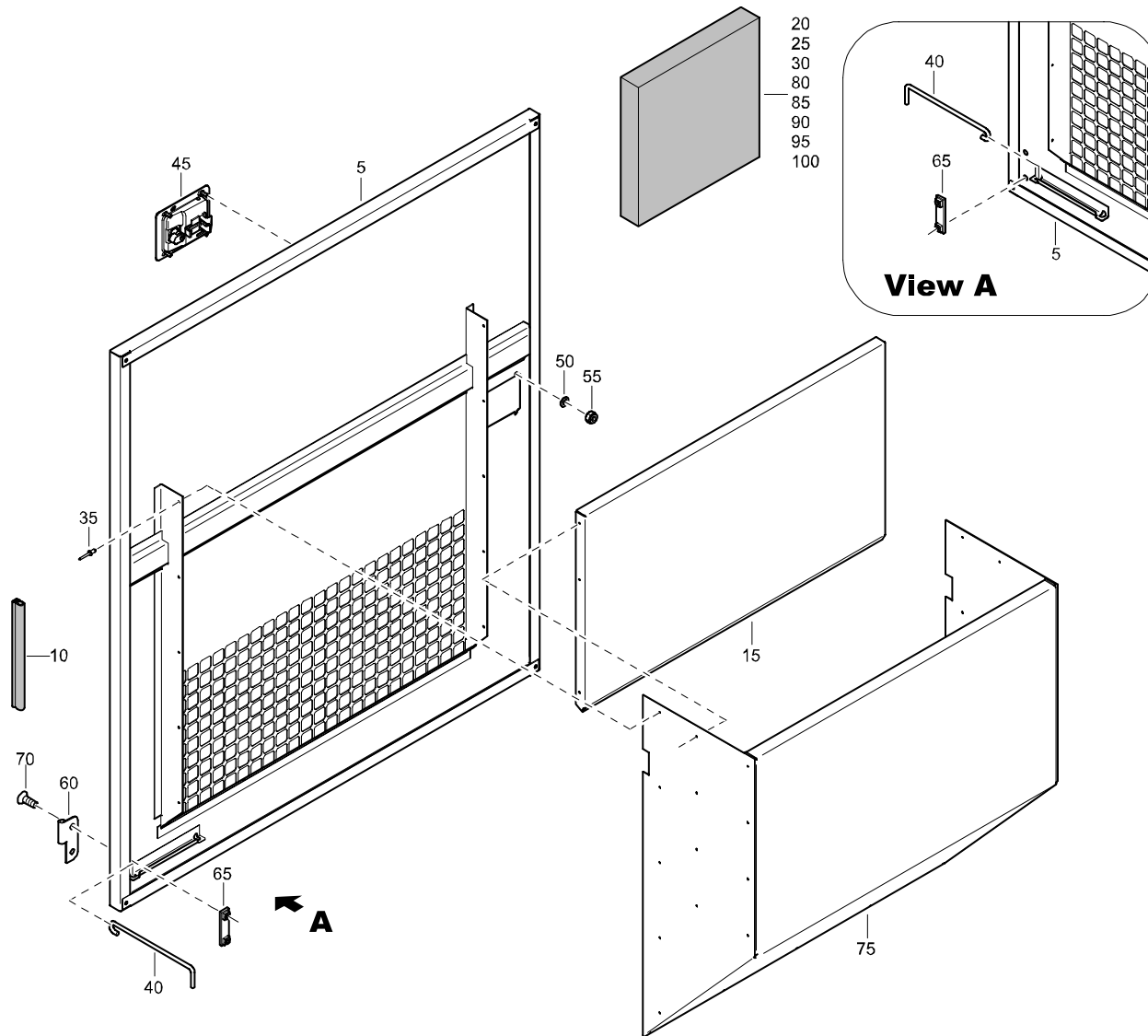

REF	PART NUMBER	DESIGNATION	QTY
-	1626 3554 81	DOOR	(From page 40)
•5	1626 3554 01	DOOR	1
•10	1604 4317 00	SEAL	AR
•15	1626 3167 01	PLATE	1
•20	-	INSULATION	3
		SILENCING FOAM (30 mm)	
•25	-	INSULATION	1
		SILENCING FOAM (30 mm)	
•30	-	INSULATION	1
		SILENCING FOAM (30 mm)	
•35	0129 3172 01	RIVET	31
•40	1626 3797 01	RETAINER	1
•45	1615 6967 03	HANDLE	1
•50	0301 2321 00	PLAIN WASHER	4
•55	0291 1108 00	LOCKNUT	4
•60	1604 3431 00	HINGE	2
•65	1615 5684 00	BRACKET	2
•70	0216 1324 03	HEX SOCK. SCREW	4
•75	1626 4436 00	BOX	1
•80	-	INSULATION	1
		SILENCING FOAM (50 mm)	
•85	-	INSULATION	1
		SILENCING FOAM (50 mm)	
•90	-	INSULATION	1
		SILENCING FOAM (30 mm)	
•95	-	INSULATION	1
		SILENCING FOAM (50 mm)	
•100	-	INSULATION	1
		SILENCING FOAM (50 mm)	
-	1079 0003 32	SILENCING FOAM 2000 mm x 1500 mm x 30 mm	
-	1079 0003 33	SILENCING FOAM 2000 mm x 1500 mm x 50 mm	

ROOF - STANDARD

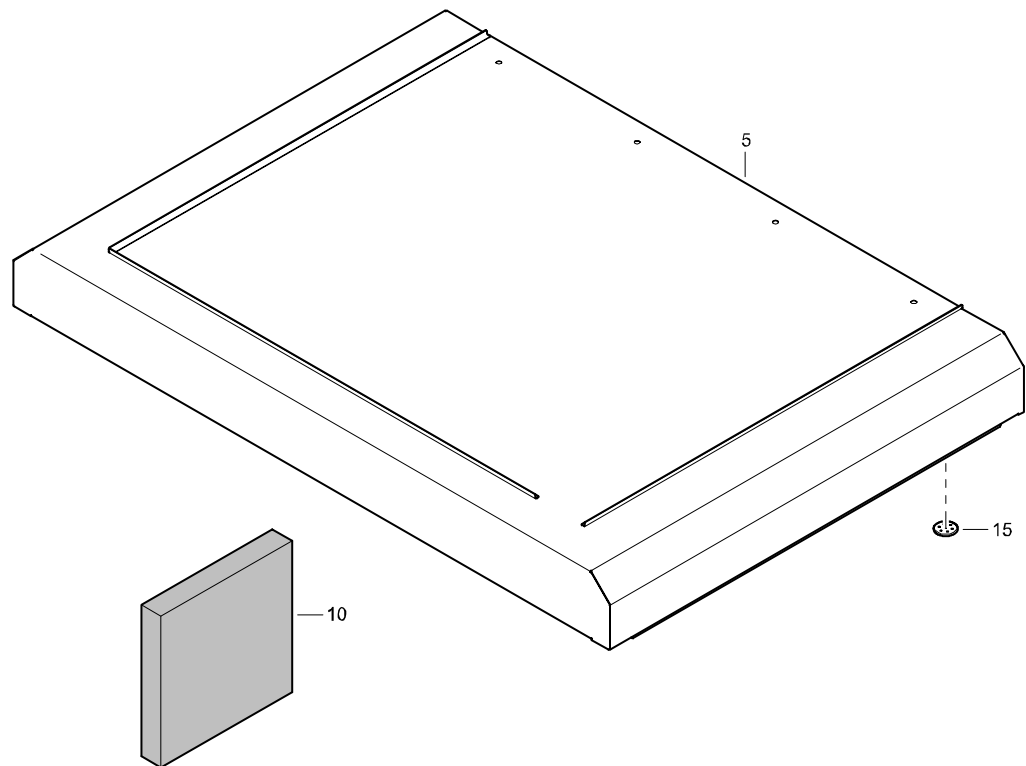

REF	PART NUMBER	DESIGNATION	QTY
-	1626 2129 81	ROOF	(From page 40)
•5	1626 2129 01	ROOF	1
•10	-	INSULATION	
		SILENCING FOAM (50 mm)	1
•15	1615 7884 00	CLIP	13
-	1079 0003 33	SILENCING FOAM 2000 mm x 1500 mm x 50 mm	

ROOF - STANDARD

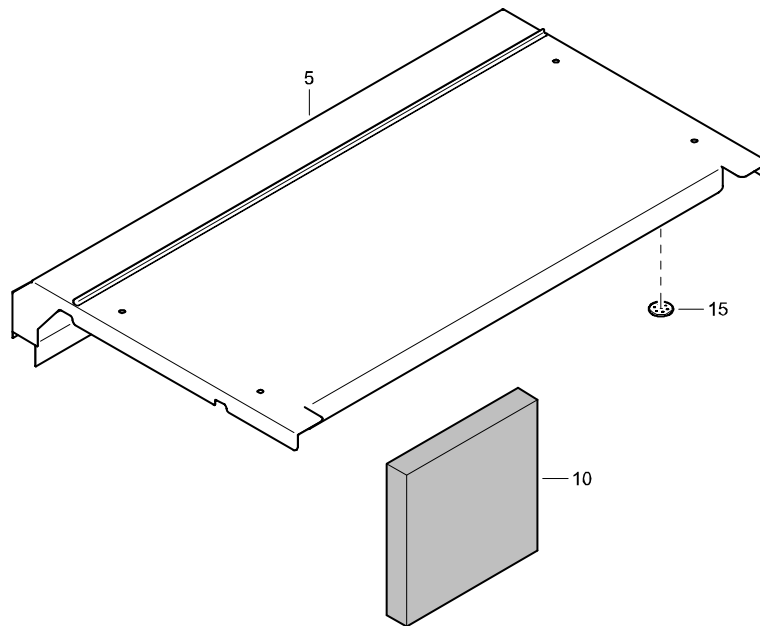

REF	PART NUMBER	DESIGNATION	QTY
-	1626 2661 81	ROOF (From page 40)	
•5	1626 2661 01	ROOF	1
•10	-	INSULATION SILENCING FOAM (50 mm)	1
•15	1615 7884 00	CLIP	6
-	1079 0003 33	SILENCING FOAM 2000 mm x 1500 mm x 50 mm	

ROOF - STANDARD

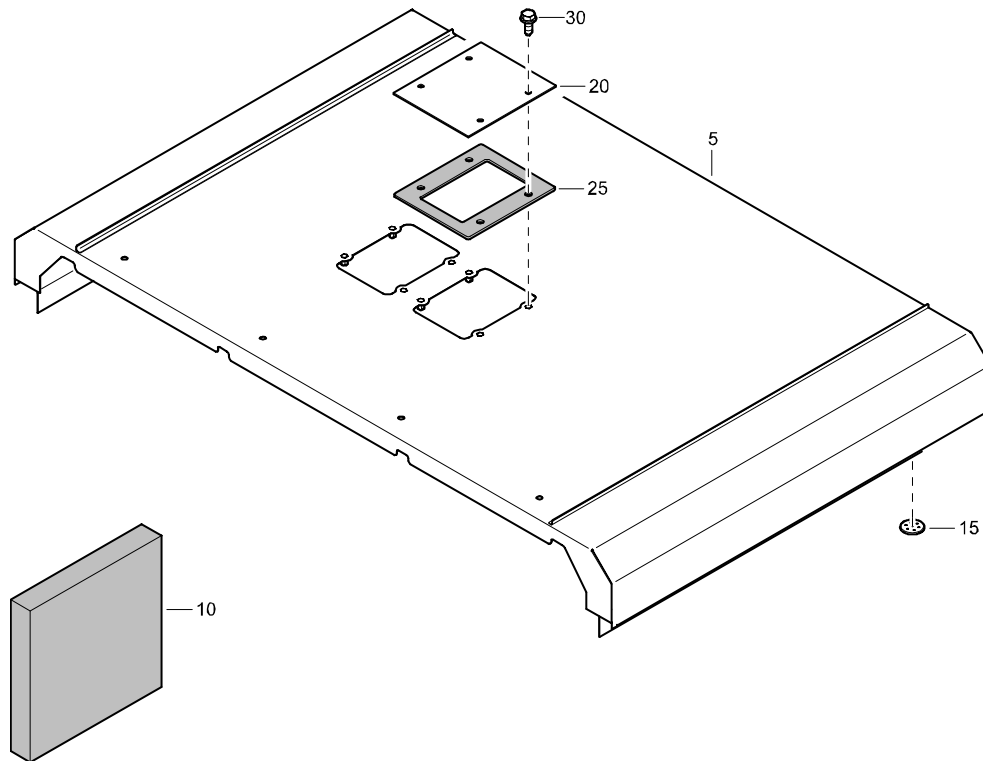

REF	PART NUMBER	DESIGNATION	QTY
-	1626 2683 81	ROOF	(From page 40)
•5	1626 2683 01	ROOF	1
•10	-	INSULATION SILENCING FOAM (50 mm)	1
•15	1615 7884 00	CLIP	13
•20	1626 3397 00	COVER COOLER	2
•25	1626 3396 00	SEAL GASKET	2
•30	1619 2766 00	HEX. HEAD SCREW	8
-	1079 0003 33	SILENCING FOAM 2000 mm x 1500 mm x 50 mm	

ROOF - STANDARD

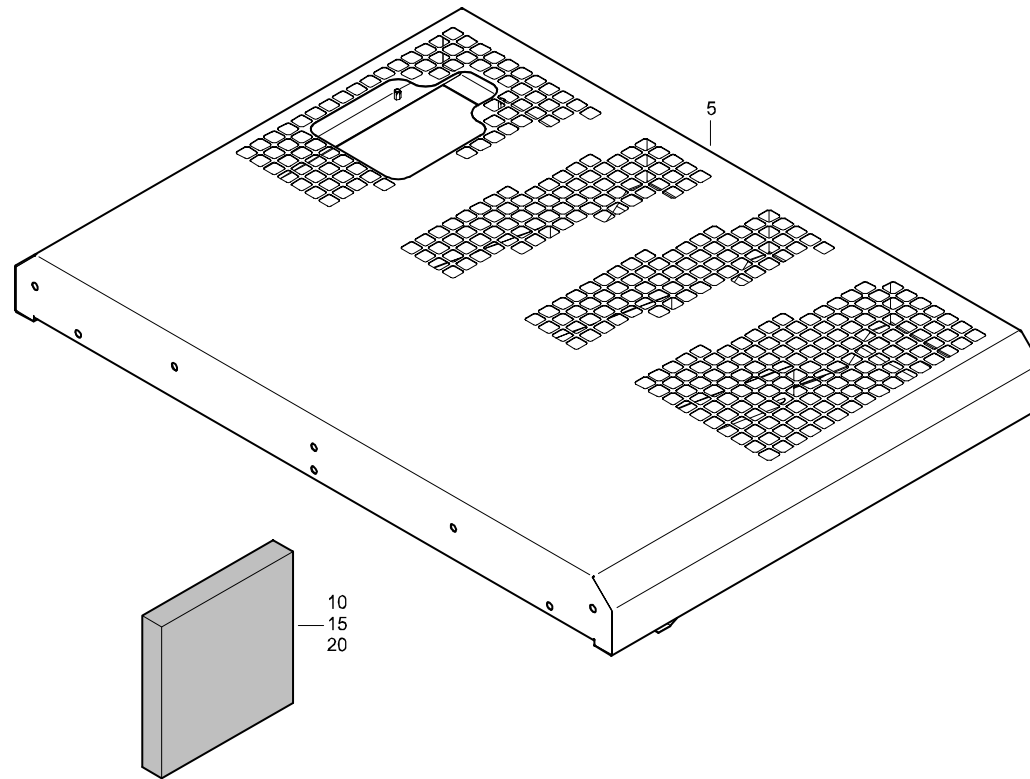

REF	PART NUMBER	DESIGNATION	QTY
-	1626 2684 81	ROOF (From page 40)	
•5	1626 2684 01	ROOF	1
•10	-	INSULATION SILENCING FOAM (50 mm)	1
•15	-	INSULATION SILENCING FOAM (50 mm)	3
•20	-	INSULATION SILENCING FOAM (50 mm)	3
-	1079 0003 33	SILENCING FOAM 2000 mm x 1500 mm x 50 mm	

BACKPLATE - STANDARD

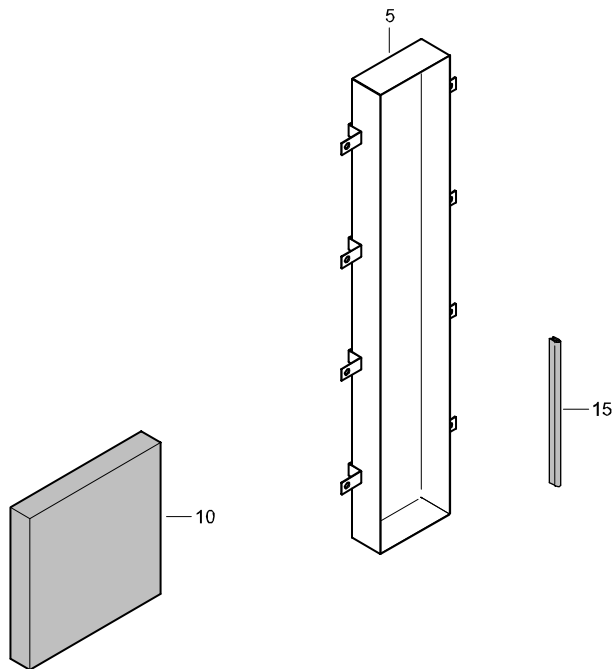

REF	PART NUMBER	DESIGNATION	QTY
-	1626 2818 81	BACKPLATE (From page 40)	
•5	1626 2818 01	BACKPLATE	1
•10	-	INSULATION SILENCING FOAM (50 mm)	1
•15	1202 6584 00	SEAL	AR
-	1079 0003 33	SILENCING FOAM 2000 mm x 1500 mm x 50 mm	

BAFFLE - STANDARD

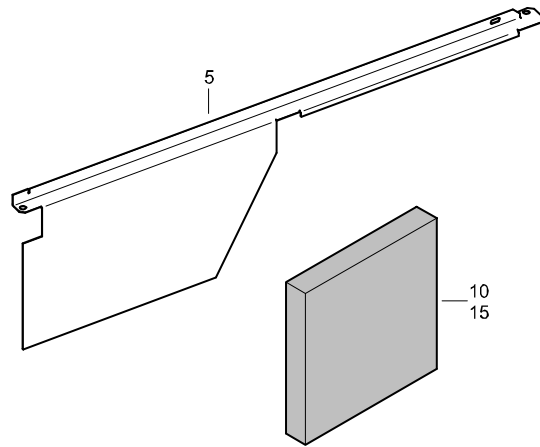

REF	PART NUMBER	DESIGNATION	QTY
-	1626 3567 81	BAFFLE (From page 40)	
•5	1626 3567 01	BAFFLE	1
•10	-	INSULATION SILENCING FOAM (50 mm)	1
•15	-	INSULATION SILENCING FOAM (50 mm)	1
-	1079 0003 33	SILENCING FOAM 2000 mm x 1500 mm x 50 mm	

BAFFLE - STANDARD

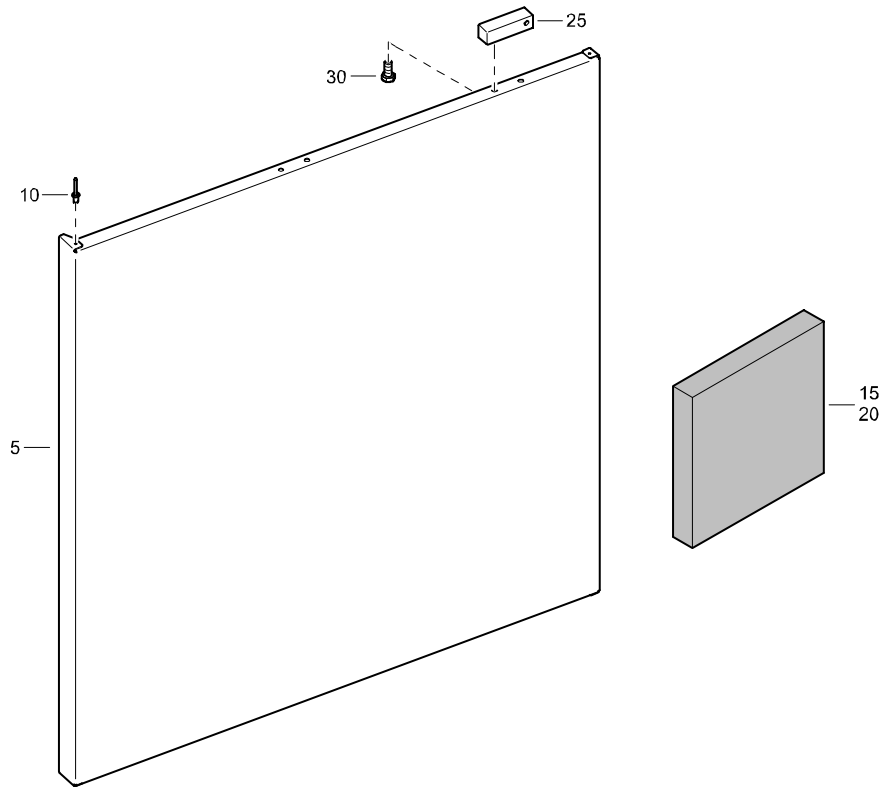

REF	PART NUMBER	DESIGNATION	QTY
-	1626 3934 81	BAFFLE	(From page 40)
•5	1626 3934 01	BAFFLE	1
•10	0129 3174 01	BLIND RIVET	4
•15	-	INSULATION	1
		SILENCING FOAM (50 mm)	
•20	-	INSULATION	1
		SILENCING FOAM (50 mm)	
•25	1626 3853 00	BLOCK	5
•30	0147 1322 03	HEX. HEAD SCREW	10
-	1079 0003 33	SILENCING FOAM 2000 mm x 1500 mm x 50 mm	

QUICK COUPLINGS - FOR EXTERNAL FUELTANK CONNECTION - OPTIONS

REF	PART NUMBER	DESIGNATION	QTY
20	1615 8745 01	QUICK COUPLING	1
25	0603 5110 03	HEXAGON NIPPLE	1
30	1615 8744 01	QUICK COUPLING	1
35	0603 4104 03	HEXAGON NIPPLE	2
45	1604 6132 00	COUPLING	1
50	1604 6133 00	COUPLING	1
55	0017 9861 53	PLASTIC BAG	1

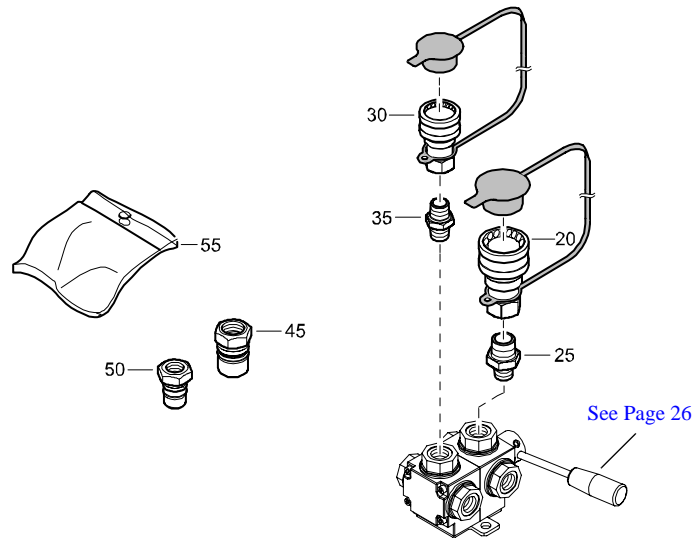

ADDITIONAL FUEL FILTER - OPTIONS

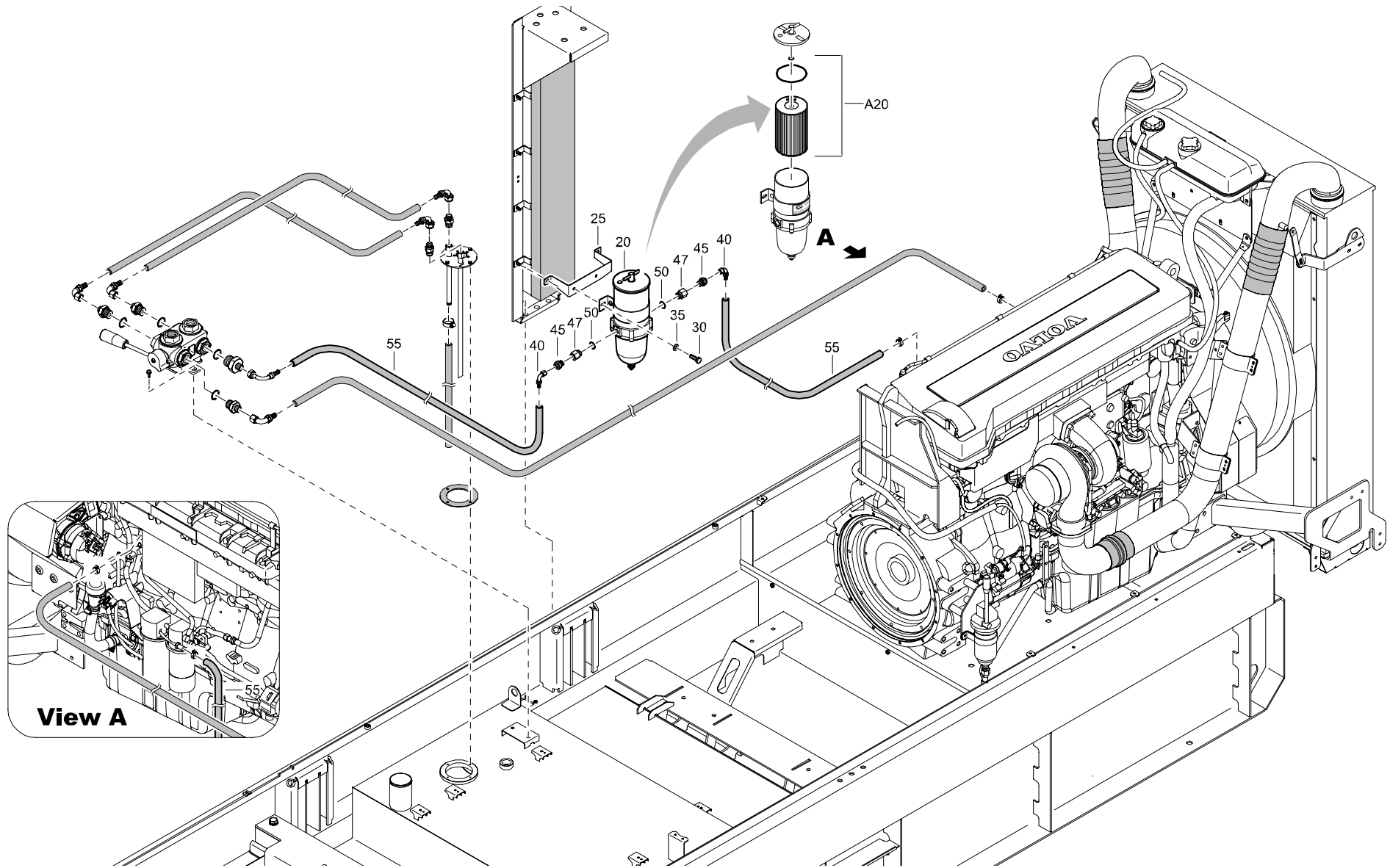

ADDITIONAL FUEL FILTER - OPTIONS

REF	PART NUMBER	DESIGNATION	QTY	REF	PART NUMBER	DESIGNATION	QTY	REF	PART NUMBER	DESIGNATION	QTY
20	1604 5491 00	FUELFILTER	1								
•A20	2914 8307 00	FUELFILTER ELEMENT	1								
25	1626 4457 00	BRACKET	1								
30	0147 1323 03	HEX. HEAD SCREW	2								
35	0301 2335 00	PLAIN WASHER	2								
40	1604 2799 00	ELBOW	2								
45	1079 5840 35	NIPPLE	2								
47	0571 0035 29	HEXAGON NIPPLE	2								
50	0653 1128 00	GASKET	2								
55	0075 4025 42	FUEL HOSE	AR								

FUEL LEVEL SENDER - OPTIONS

REF	PART NUMBER	DESIGNATION	QTY
20	1626 3884 01	SENSOR LEVEL	1

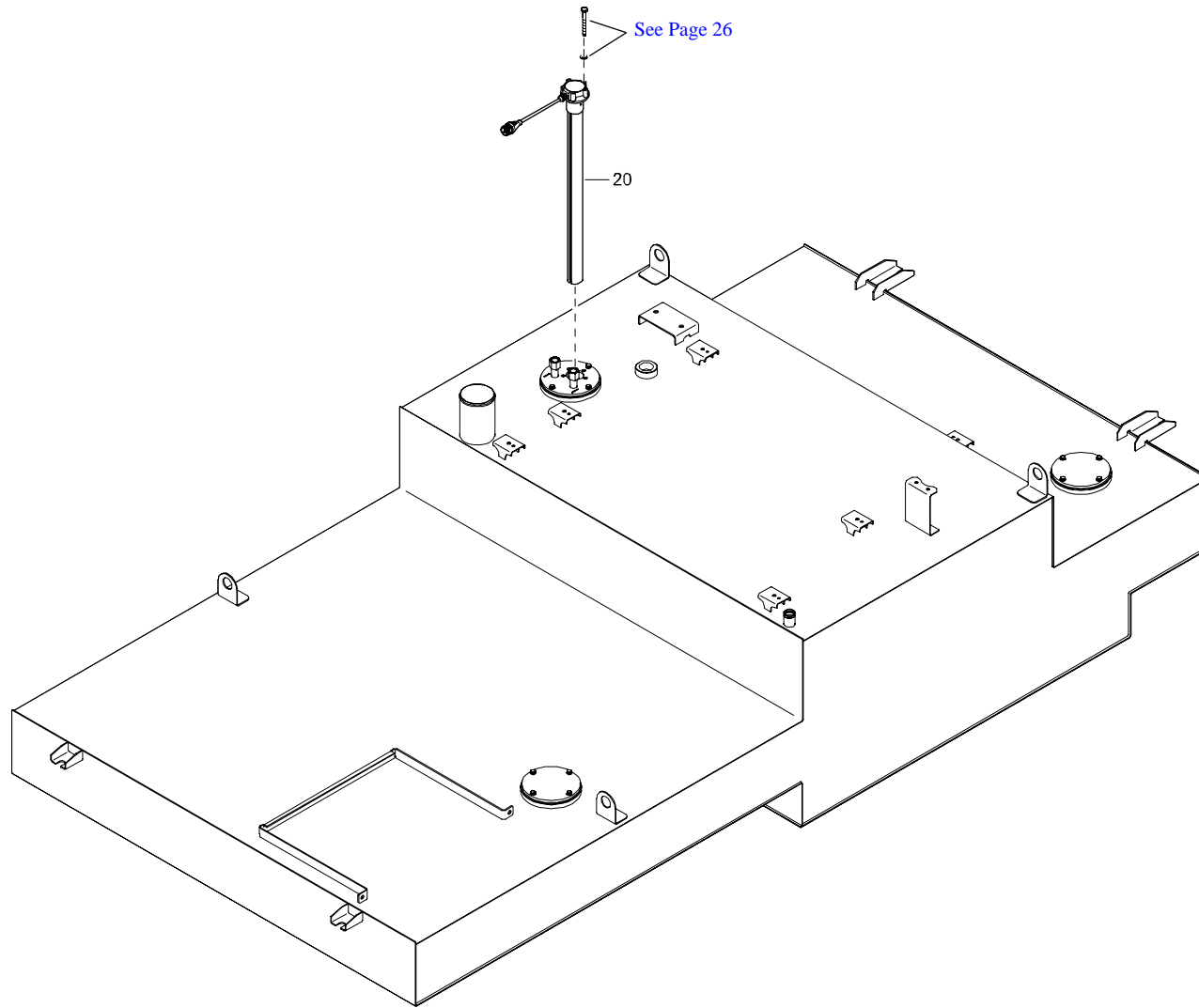

CUBICLE - 400V - OPTIONS

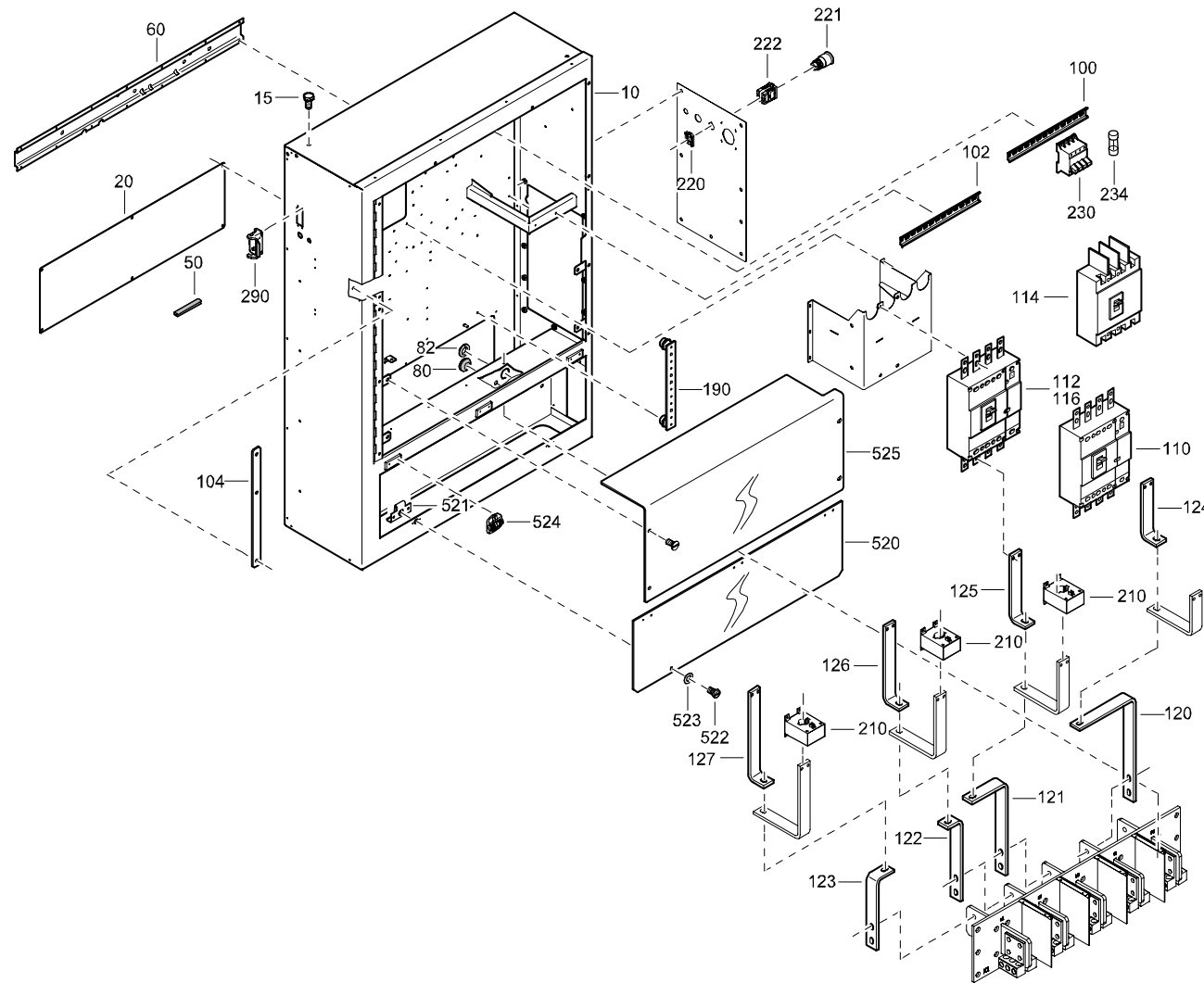

REF	PART NUMBER	DESIGNATION	QTY
10	1626 2678 01	BOX	1
15	0147 1320 03	HEX. HEAD SCREW	2
20	1626 2824 00	PLATE	1
50	1503 1056 00	SEAL	AR
60	1626 4301 00	PROFILE	1
80	1088 0801 10	GROMMET	1
82	1088 0801 31	GROMMET	1
100	0993 7106 00	MOUNTING RAIL	AR
102	0993 7106 00	MOUNTING RAIL	AR
104	1626 2826 00	BRACKET	2
110	1089 9474 45	CIRCUIT BREAK.	1
112	1089 9474 42	UNDERVOLTAGE TRIP COIL	1
114	1089 9474 95	CONTACT	1
116	1089 9474 19	MOTOR DRIVE	1
120	1626 3512 00	TERMINAL	1
121	1626 3513 00	TERMINAL	1
122	1626 3514 00	TERMINAL	1
123	1626 3515 00	TERMINAL	1
124	1626 3516 00	TERMINAL	1
125	1626 3517 00	TERMINAL	1
126	1626 3518 00	TERMINAL	1
127	1626 3519 00	TERMINAL	1
190	1604 2285 00	EARTH RAIL ASS'Y	1
210	1089 9357 73	TRANSFORMER	3
220	1089 9622 04	SWITCH SELECTOR	1
221	1089 9622 09	ACTUATOR	1
222	1089 9622 08	CONTACT	2
230	1089 9356 11	FUSE HOLDER	2
234	1089 9332 07	FUSE	6
290	1088 0029 50	HOUSING	1
520	1626 2825 01	SCREEN	1
521	1615 6728 00	PLATE	2
522	1615 7166 00	STUD	2
523	1615 6727 00	WASHER	2
524	1604 4146 00	HINGE	3
525	1626 3889 01	COVER	1

PLATES - FOR GENERATOR WITH NO SOCKETS - QC 4002 - OPTIONS

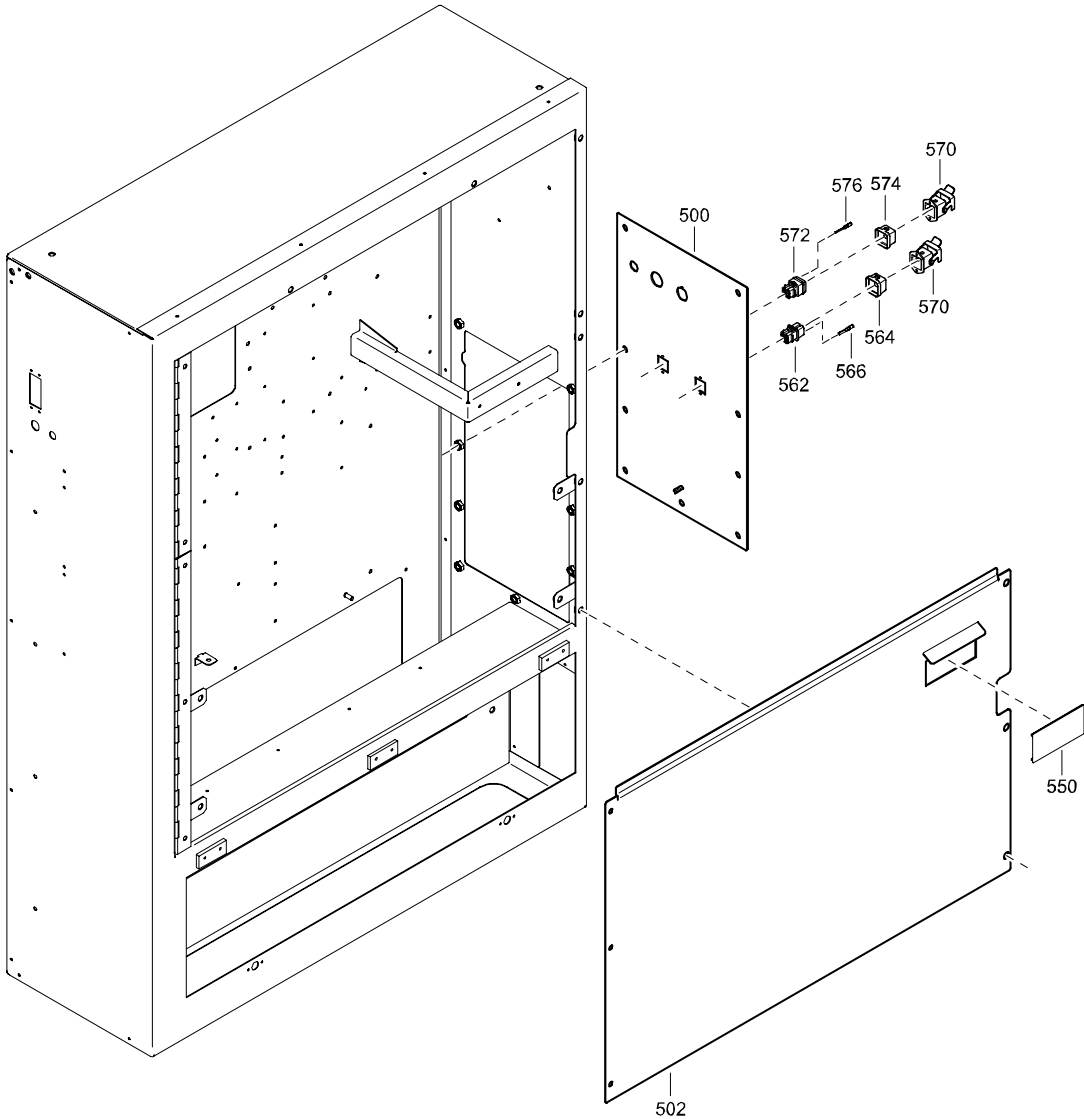

REF	PART NUMBER	DESIGNATION	QTY
500	1626 1154 01	PLATE	1
502	1626 2680 01	PLATE	1
550	1088 0500 05	COVER PLATE	AR
562	1088 0029 44	FEMALE INSERT	1
564	1088 0029 68	PROTECT.COVER	1
566	1088 0029 63	FEMALE CONTACT	3
570	1088 0029 60	HOUSING	2
572	1088 0029 43	MALE INSERT	1
574	1088 0029 66	PROTECT.COVER	1
576	1088 0029 61	MALE CONTACT	3

TERMINAL BOARD - OPTIONS

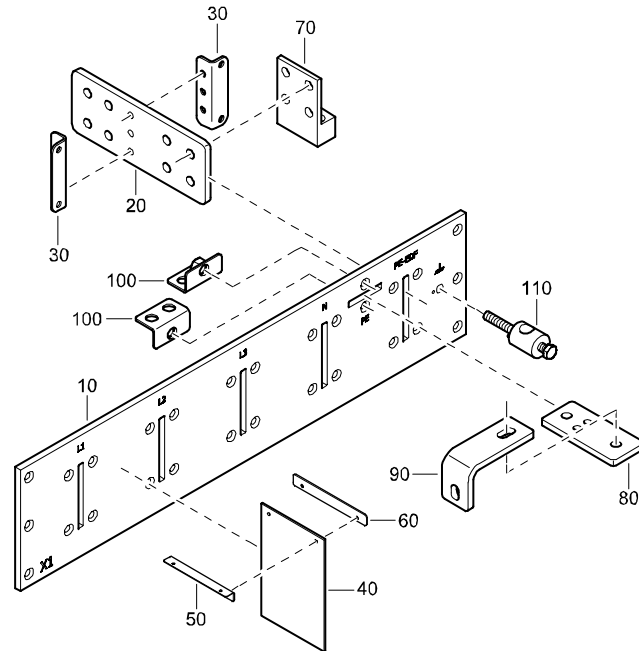

REF	PART NUMBER	DESIGNATION	QTY
10	1626 3658 01	ISOLATOR	1
20	1626 2828 00	TERMINAL	5
30	1626 3666 00	BRACKET	10
40	1626 2821 00	ISOLATOR	3
50	1626 2822 00	BRACKET	3
60	1626 2823 00	PLATE	3
70	1089 0651 05	TERMINAL	5
80	1626 3661 00	TERMINAL	1
90	1626 3662 00	TERMINAL	1
100	1626 1401 00	BRACKET	2
110	1615 8893 00	TERMINAL	1

SOCKETS - 1 PH CEE QC 4002 - OPTIONS

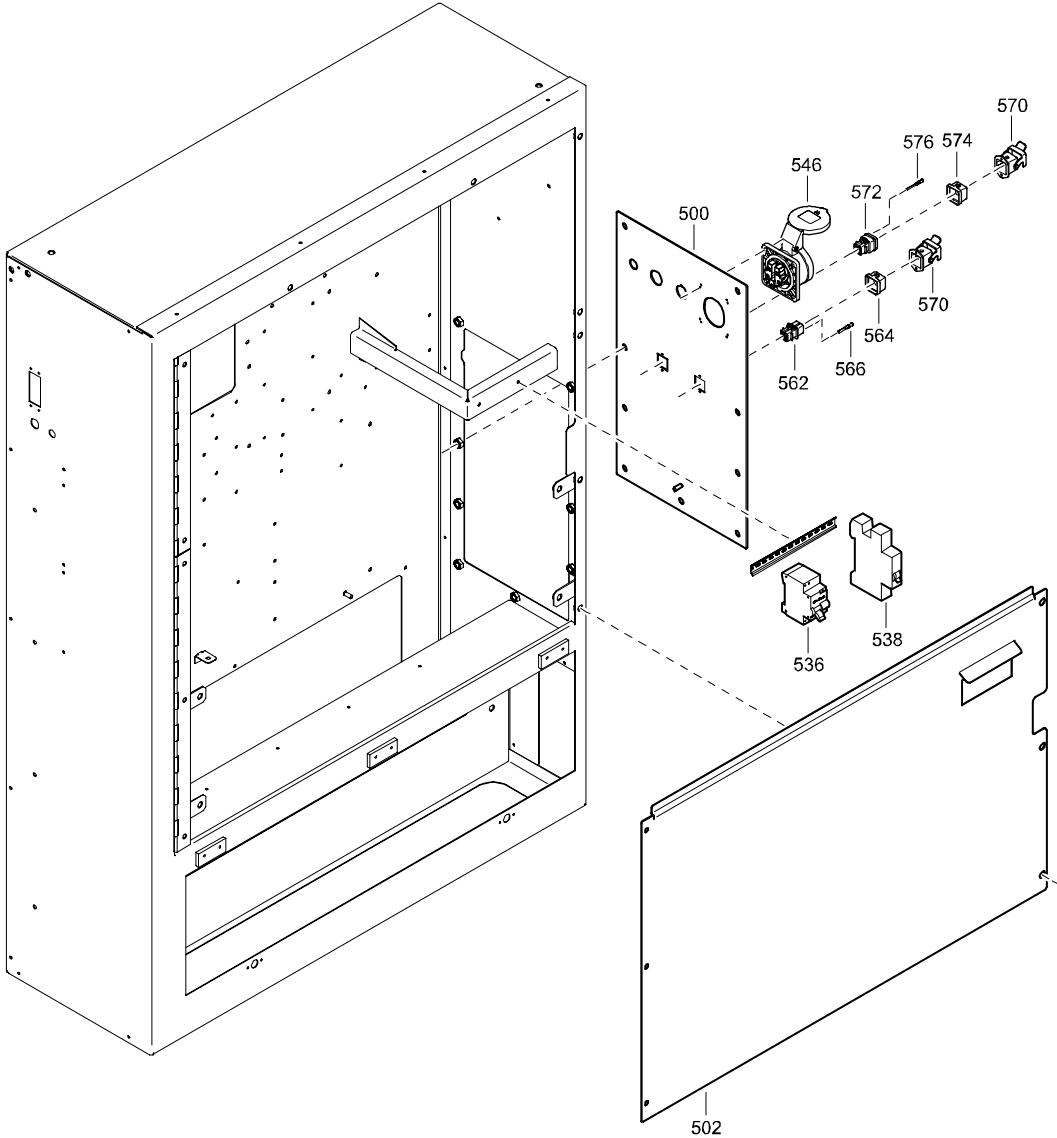

REF	PART NUMBER	DESIGNATION	QTY
500	1626 1340 01	PLATE	1
502	1626 2680 01	PLATE	1
536	1089 9473 01	CIRCUIT BREAKER	1
538	1089 9473 13	SHUNT TRIP COIL	1
546	1089 0662 11	SOCKET OUTLET	1
562	1088 0029 44	FEMALE INSERT	1
564	1088 0029 68	PROTECT.COVER	1
566	1088 0029 63	FEMALE CONTACT	3
570	1088 0029 60	HOUSING	2
572	1088 0029 43	MALE INSERT	1
574	1088 0029 66	PROTECT.COVER	1
576	1088 0029 61	MALE CONTACT	3

SOCKETS - 1 PH RIM QC 4002 - OPTIONS

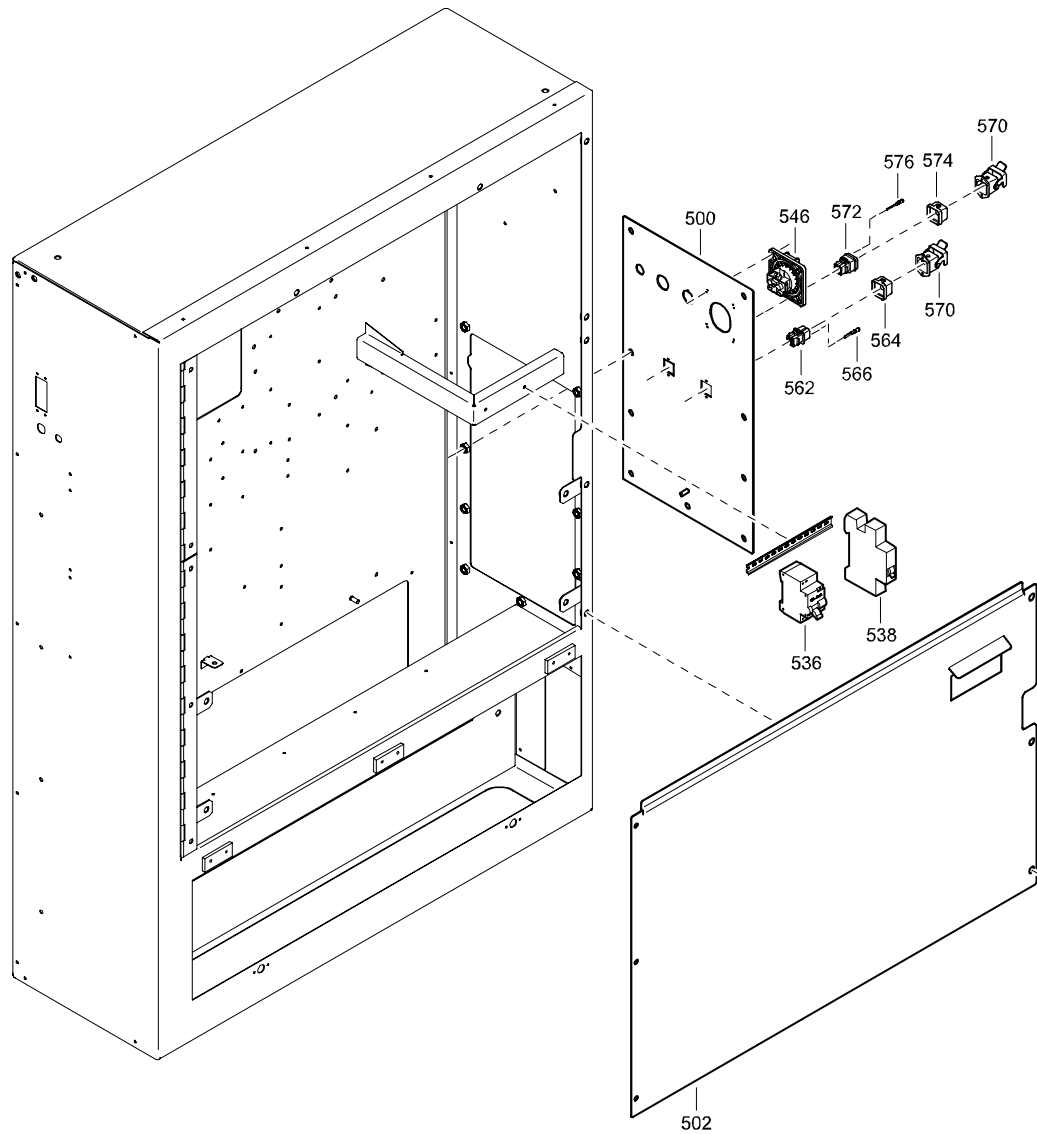

REF	PART NUMBER	DESIGNATION	QTY
500	1626 1340 01	PLATE	1
502	1626 2680 01	PLATE	1
536	1089 9473 01	CIRCUIT BREAKER	1
538	1089 9473 13	SHUNT TRIP COIL	1
546	1089 0662 01	SOCKET OUTLET	1
562	1088 0029 44	FEMALE INSERT	1
564	1088 0029 68	PROTECT.COVER	1
566	1088 0029 63	FEMALE CONTACT	3
570	1088 0029 60	HOUSING	2
572	1088 0029 43	MALE INSERT	1
574	1088 0029 66	PROTECT.COVER	1
576	1088 0029 61	MALE CONTACT	3

SOCKETS - 1 PH PIN QC4002 - OPTIONS

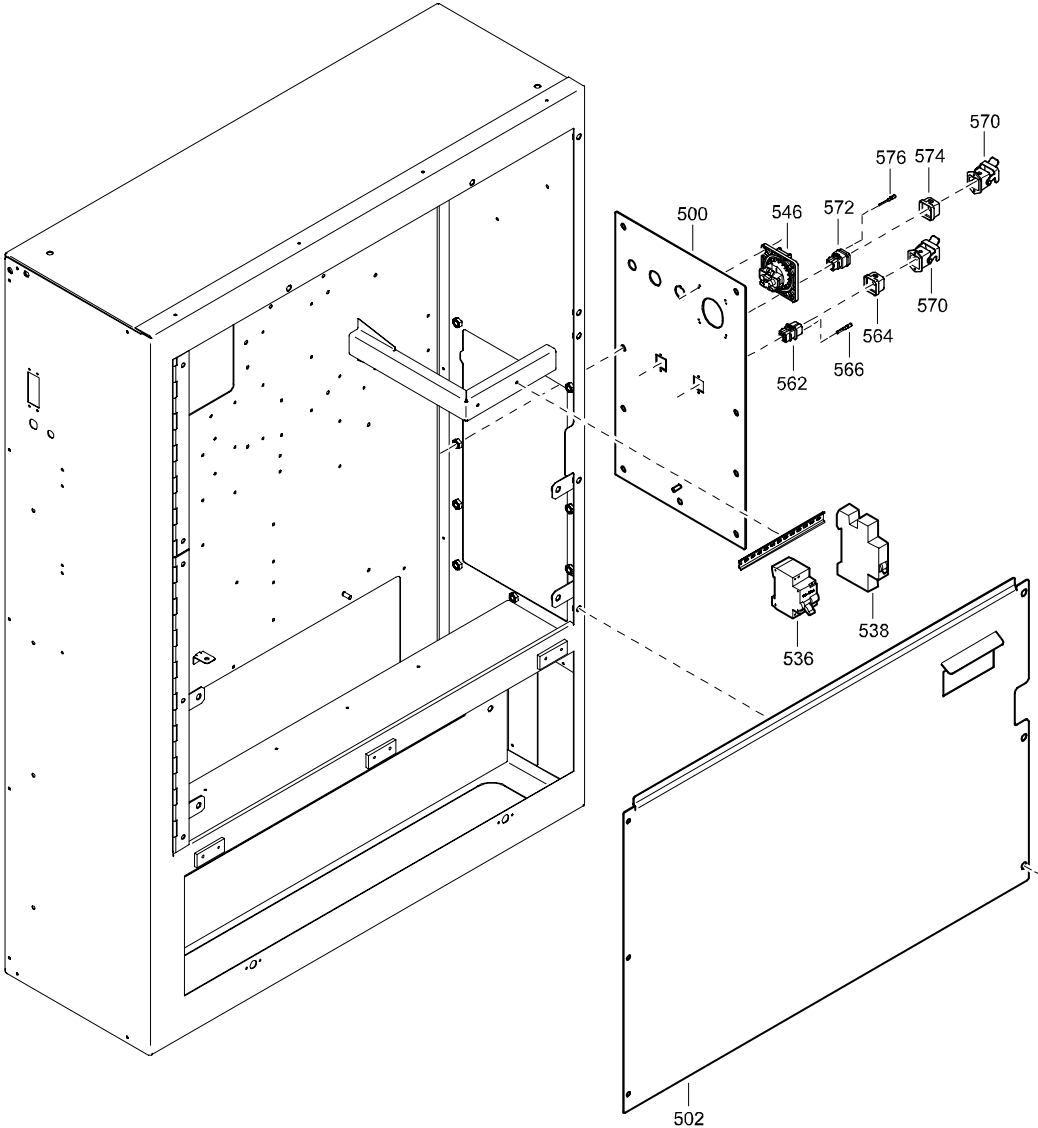

REF	PART NUMBER	DESIGNATION	QTY
500	1626 1340 01	PLATE	1
502	1626 2680 01	PLATE	1
536	1089 9473 01	CIRCUIT BREAKER	1
538	1089 9473 13	SHUNT TRIP COIL	1
546	1089 0662 29	SOCKET OUTLET	1
562	1088 0029 44	FEMALE INSERT	1
564	1088 0029 68	PROTECT.COVER	1
566	1088 0029 63	FEMALE CONTACT	3
570	1088 0029 60	HOUSING	2
572	1088 0029 43	MALE INSERT	1
574	1088 0029 66	PROTECT.COVER	1
576	1088 0029 61	MALE CONTACT	3

SOCKETS - 1 PH CEE - OPTIONS

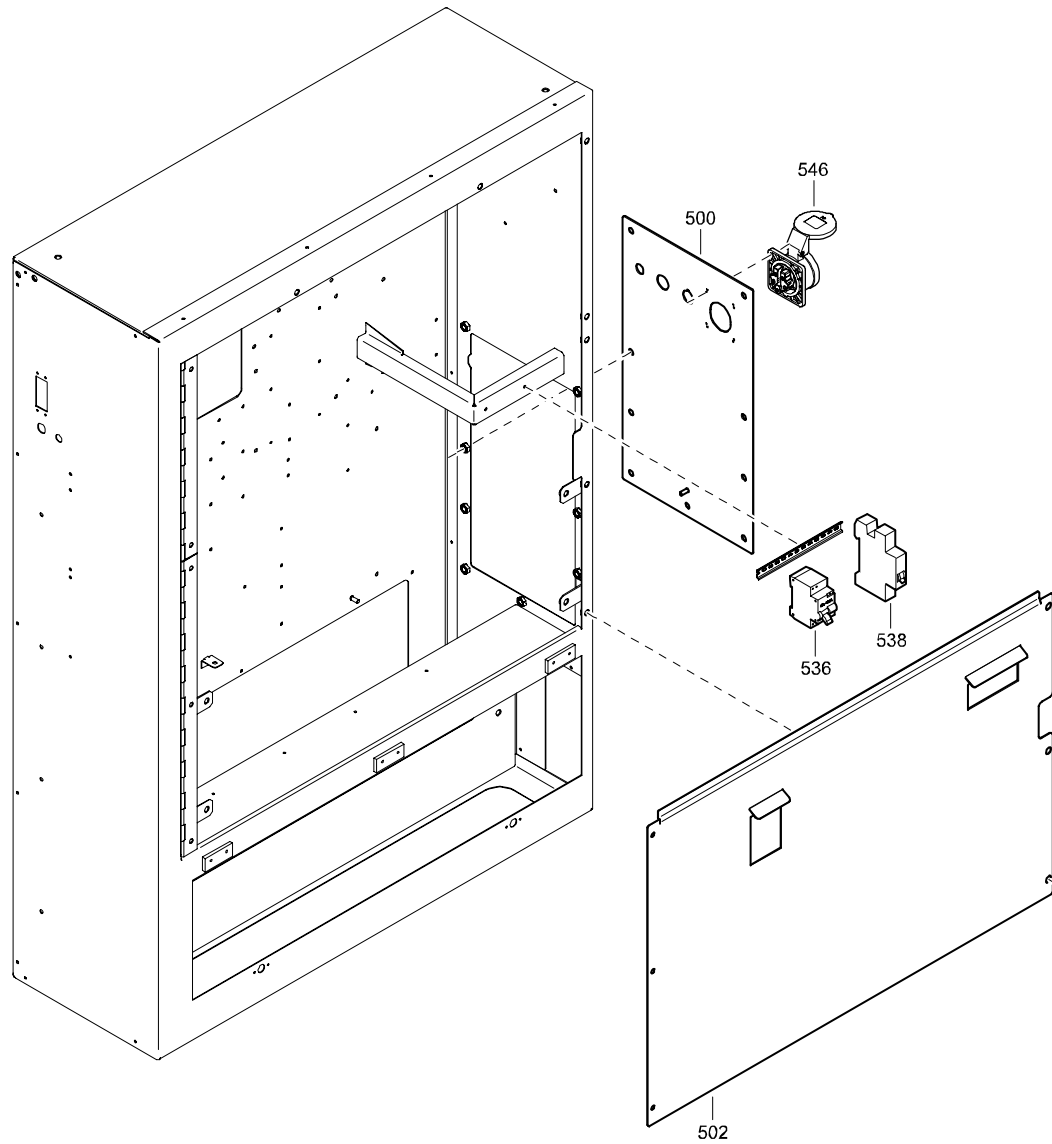

REF	PART NUMBER	DESIGNATION	QTY
500	1626 0485 01	PLATE	1
502	1626 4246 00	PANEL	1
536	1089 9473 01	CIRCUIT BREAKER	1
538	1089 9473 13	SHUNT TRIP COIL	1
546	1089 0662 11	SOCKET OUTLET	1

SOCKETS - 1 PH RIM - OPTIONS

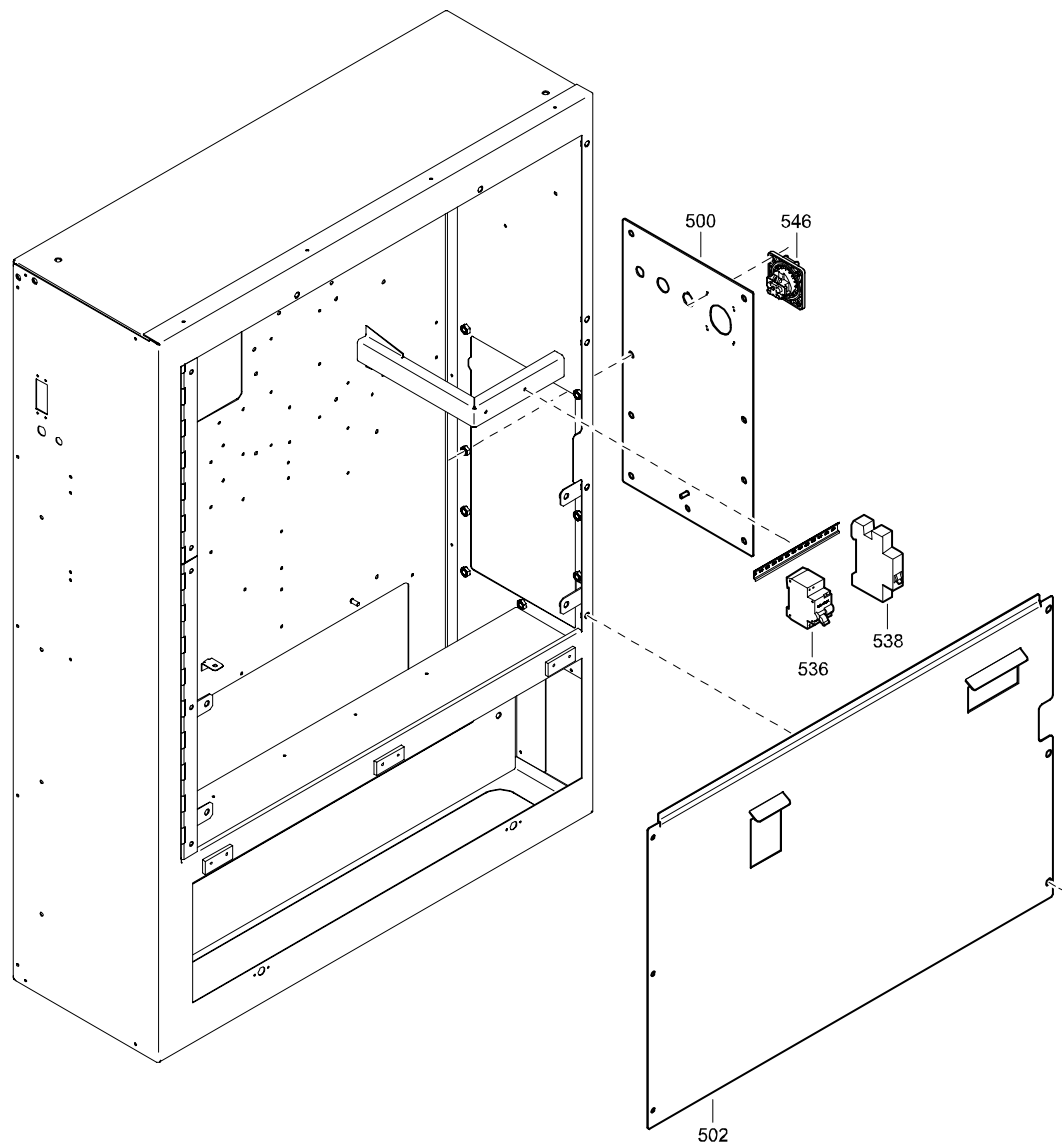

REF	PART NUMBER	DESIGNATION	QTY
500	1626 0485 01	PLATE	1
502	1626 4246 00	PANEL	1
536	1089 9473 01	CIRCUIT BREAKER	1
538	1089 9473 13	SHUNT TRIP COIL	1
546	1089 0662 01	SOCKET OUTLET	1

SOCKETS - 1 PH PIN - OPTIONS

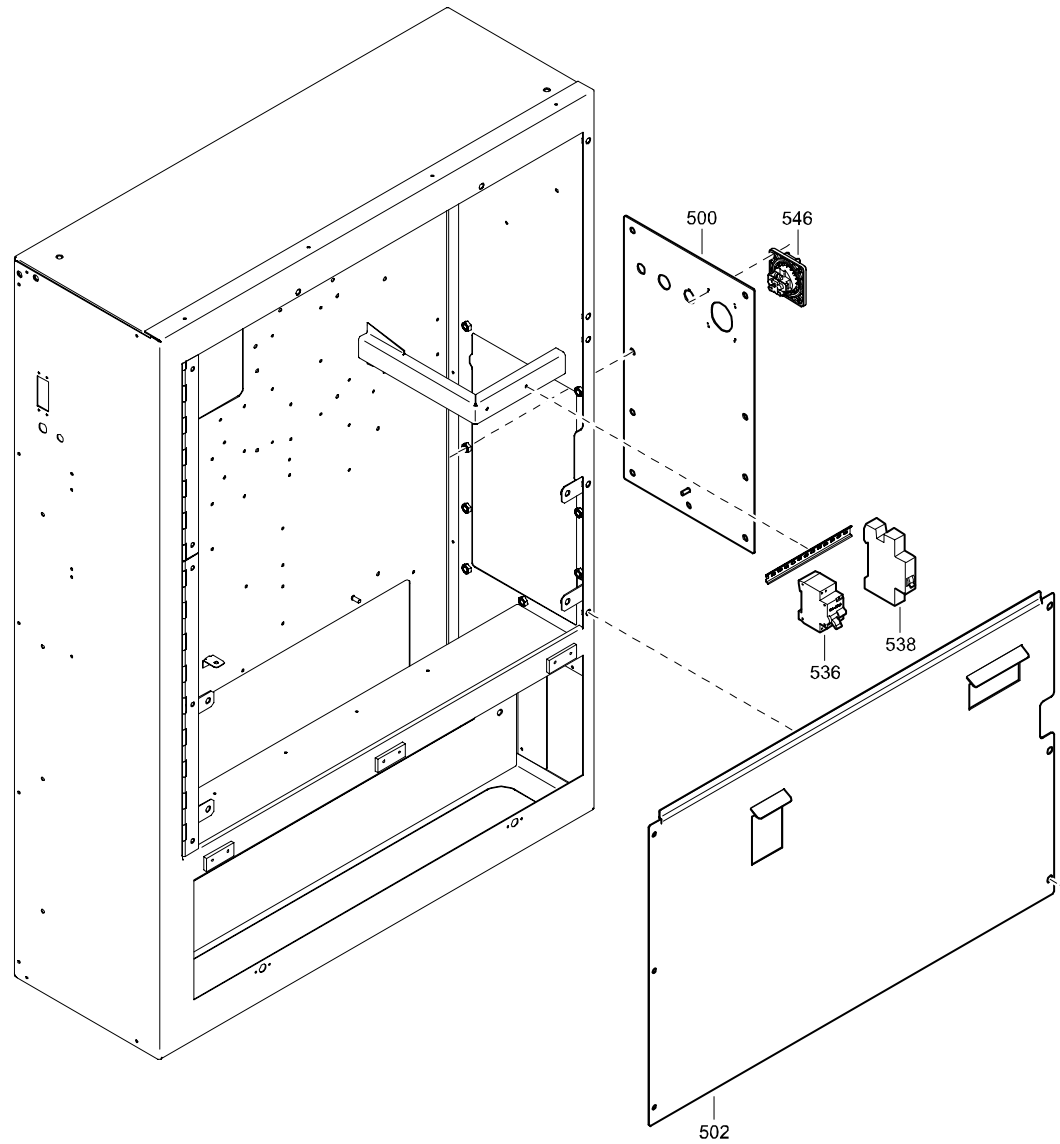

REF	PART NUMBER	DESIGNATION	QTY
500	1626 0485 01	PLATE	1
502	1626 4246 00	PANEL	1
536	1089 9473 01	CIRCUIT BREAKER	1
538	1089 9473 13	SHUNT TRIP COIL	1
546	1089 0662 29	SOCKET OUTLET	1

SOCKETS - 3 PH - OPTIONS

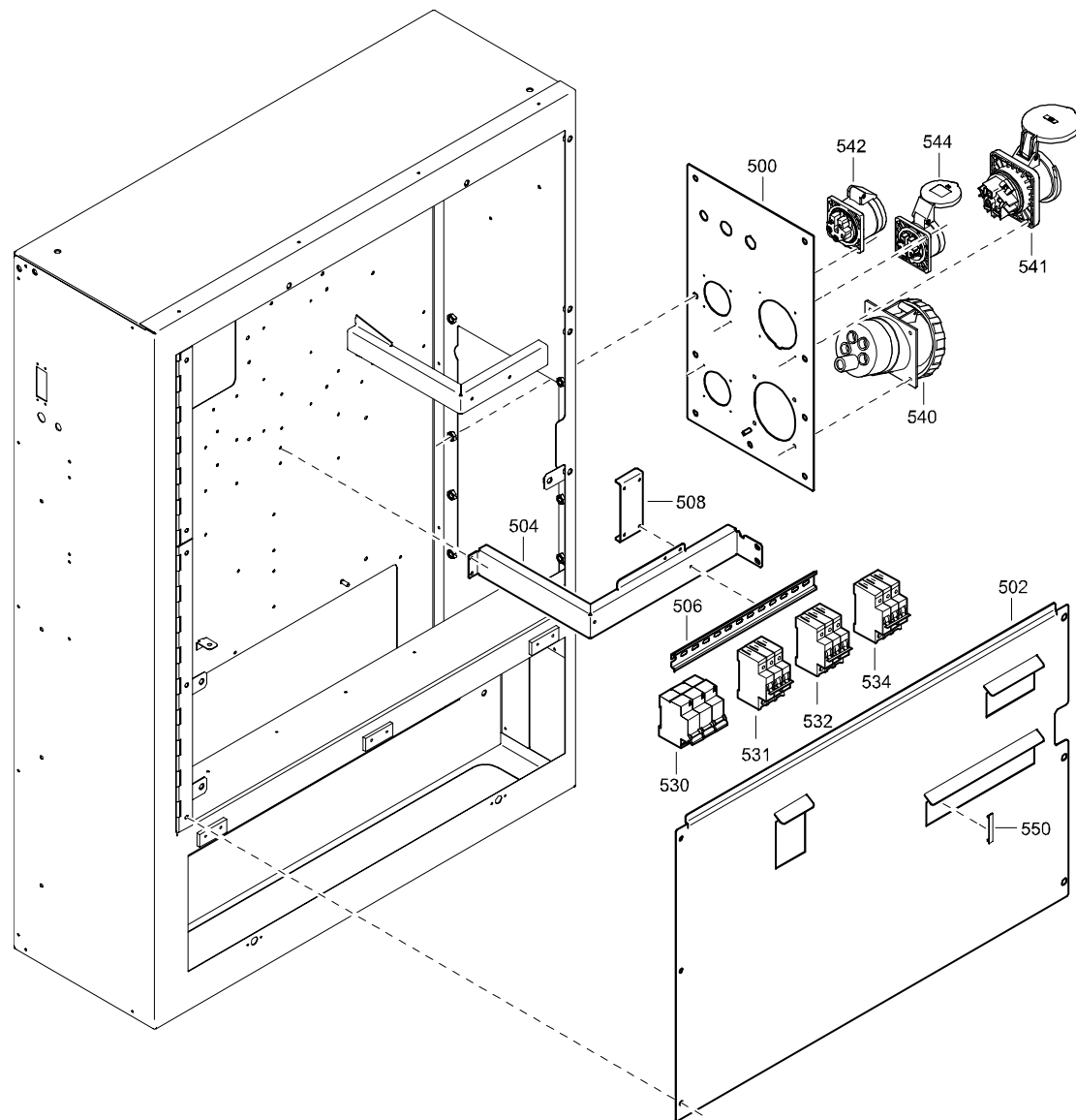

REF	PART NUMBER	DESIGNATION	QTY
500	1626 2030 01	PLATE	1
502	1626 3674 01	PLATE	1
504	1626 3670 01	BRACKET	1
506	0993 7106 00	MOUNTING RAIL	AR
508	1626 4276 00	PLATE	1
530	1089 9472 66	CIRCUIT BREAKER	1
531	1089 9472 28	CIRCUIT BREAKER	1
532	1089 9472 27	CIRCUIT BREAKER	1
534	1089 9472 26	CIRCUIT BREAKER	1
540	1089 0662 37	SOCKET OUTLET	1
541	1089 0662 07	SOCKET OUTLET	1
542	1089 0662 04	SOCKET OUTLET	1
544	1089 0662 12	SOCKET OUTLET	1
550	1088 0500 05	COVER PLATE	AR

SOCKETS - 1 PH CEE + 3 PH - OPTIONS

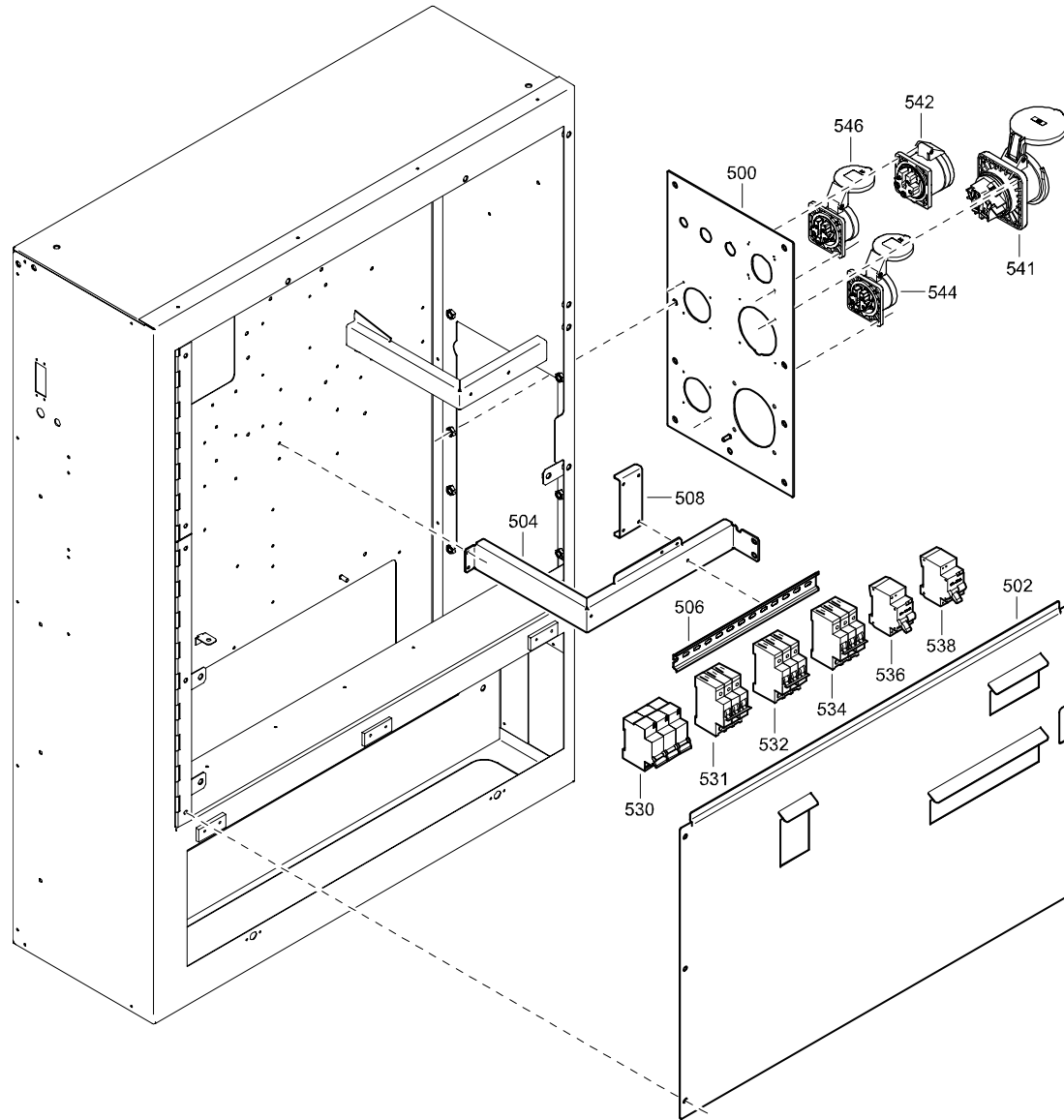

REF	PART NUMBER	DESIGNATION	QTY
500	1626 1959 01	PLATE	1
502	1626 3674 01	PLATE	1
504	1626 3670 01	BRACKET	1
506	0993 7106 00	MOUNTING RAIL	AR
508	1626 4276 00	PLATE	1
530	1089 9472 66	CIRCUIT BREAKER	1
531	1089 9472 28	CIRCUIT BREAKER	1
532	1089 9472 27	CIRCUIT BREAKER	1
534	1089 9472 26	CIRCUIT BREAKER	1
536	1089 9473 01	CIRCUIT BREAKER	1
538	1089 9473 13	SHUNT TRIP COIL	1
541	1089 0662 07	SOCKET OUTLET	1
542	1089 0662 04	SOCKET OUTLET	1
544	1089 0662 12	SOCKET OUTLET	1
546	1089 0662 11	SOCKET OUTLET	1

SOCKETS - 1 PH RIM + 3 PH - OPTIONS

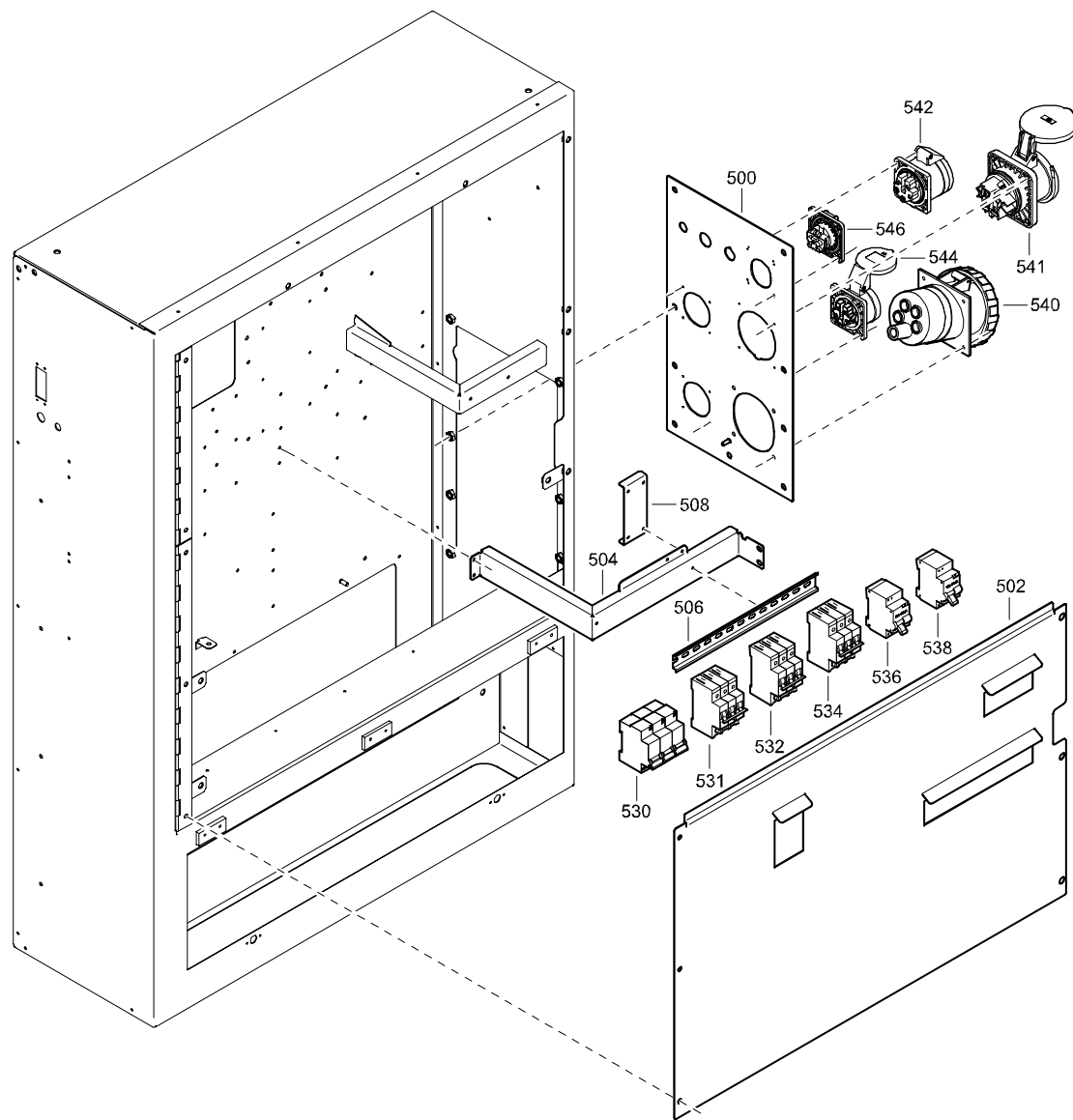

REF	PART NUMBER	DESIGNATION	QTY
500	1626 1959 01	PLATE	1
502	1626 3674 01	PLATE	1
504	1626 3670 01	BRACKET	1
506	0993 7106 00	MOUNTING RAIL	AR
508	1626 4276 00	PLATE	1
530	1089 9472 66	CIRCUIT BREAKER	1
531	1089 9472 28	CIRCUIT BREAKER	1
532	1089 9472 27	CIRCUIT BREAKER	1
534	1089 9472 26	CIRCUIT BREAKER	1
536	1089 9473 01	CIRCUIT BREAKER	1
538	1089 9473 13	SHUNT TRIP COIL	1
540	1089 0662 37	SOCKET OUTLET	1
541	1089 0662 07	SOCKET OUTLET	1
542	1089 0662 04	SOCKET OUTLET	1
544	1089 0662 12	SOCKET OUTLET	1
546	1089 0662 01	SOCKET OUTLET	1

SOCKETS - 1 PH PIN + 3 PH - OPTIONS

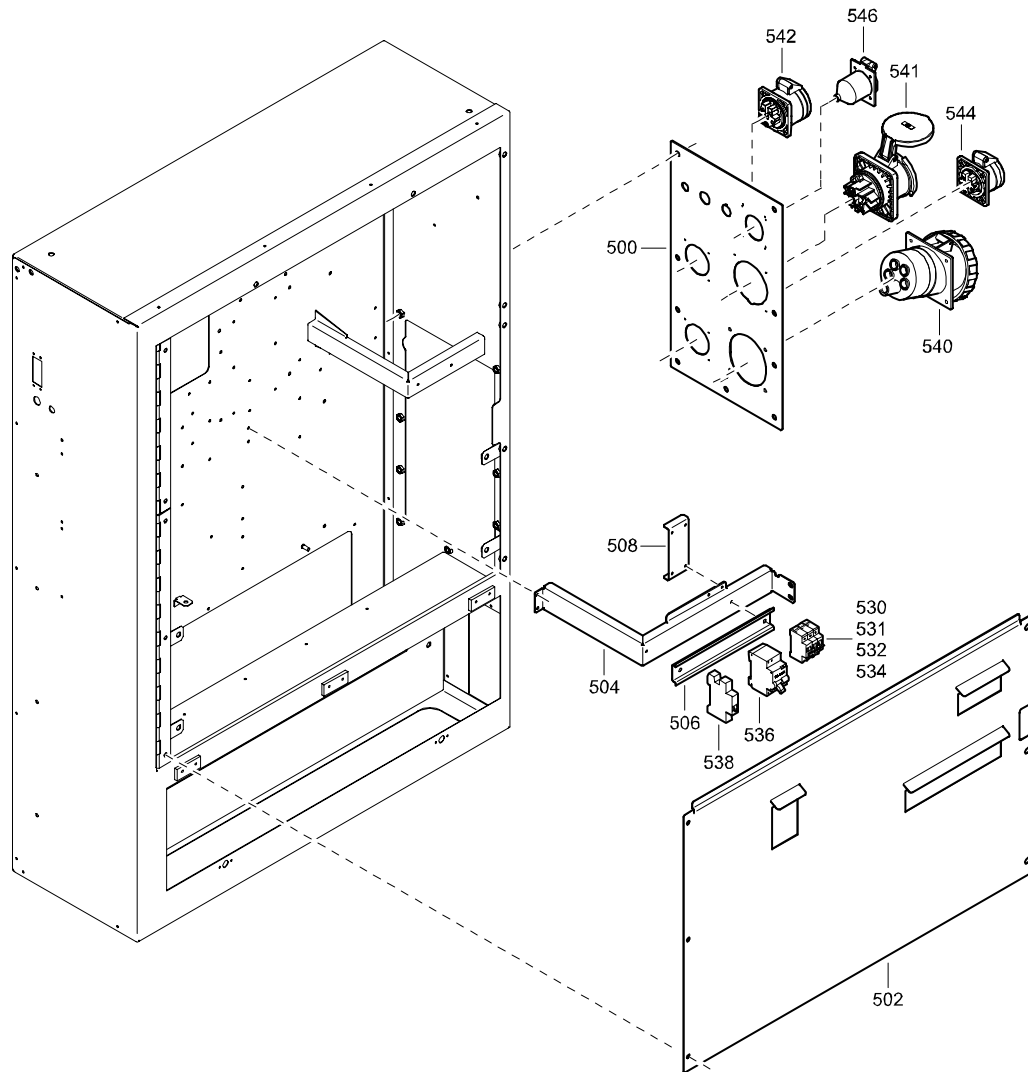

REF	PART NUMBER	DESIGNATION	QTY
500	1626 1959 01	PLATE	1
502	1626 3674 01	PLATE	1
504	1626 3670 01	BRACKET	1
506	0993 7106 00	MOUNTING RAIL	AR
508	1626 4276 00	PLATE	1
530	1089 9472 66	CIRCUIT BREAKER	1
531	1089 9661 05	CIRCUIT BREAK.	1
532	1089 9661 04	CIRCUIT BREAK.	1
534	1089 9661 03	CIRCUIT BREAK.	1
536	1089 9473 01	CIRCUIT BREAKER	1
538	1089 9473 13	SHUNT TRIP COIL	1
540	1089 0662 37	SOCKET OUTLET	1
541	1089 0662 07	SOCKET OUTLET	1
542	1089 0662 04	SOCKET OUTLET	1
544	1089 0662 12	SOCKET OUTLET	1
546	1089 0662 29	SOCKET OUTLET	1

CONTROL PANEL - QC2002 PACK 800A - OPTIONS

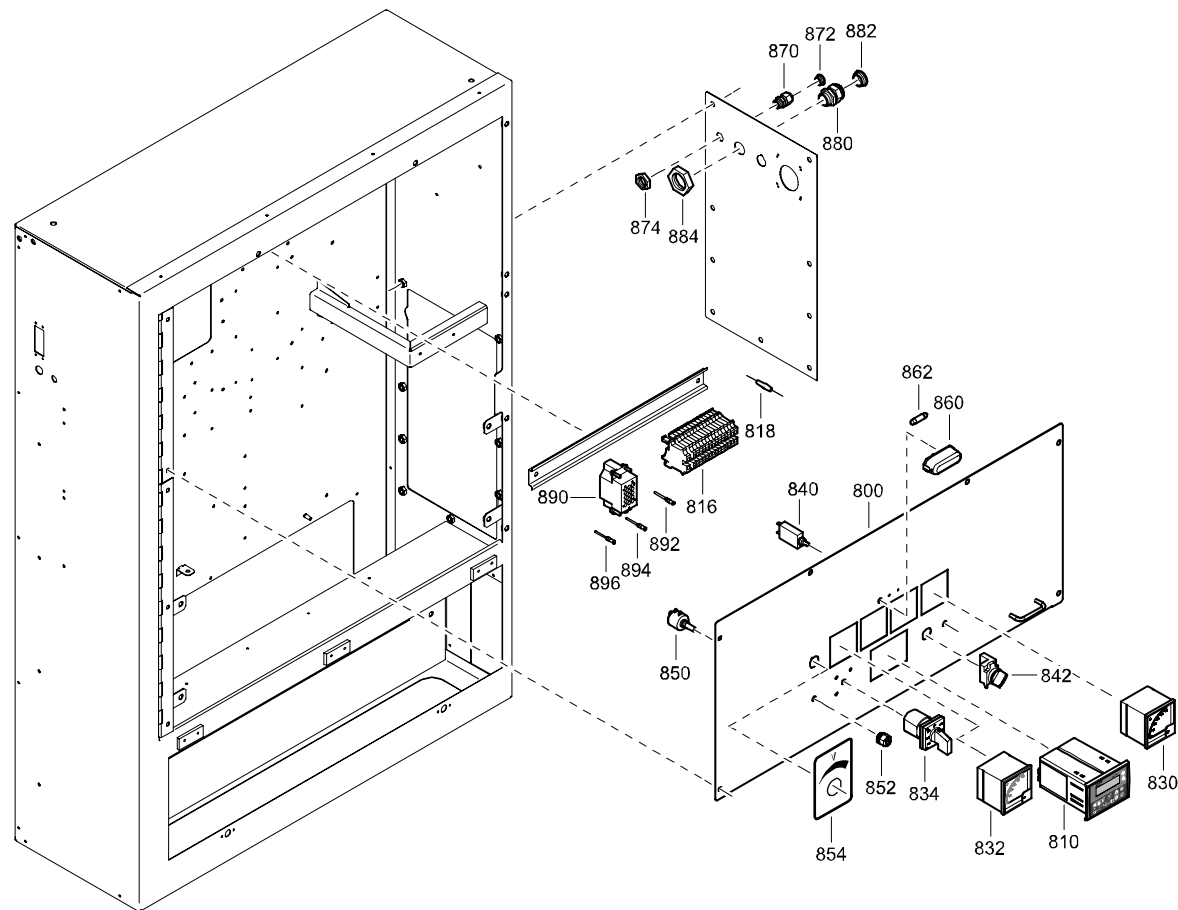

REF	PART NUMBER	DESIGNATION	QTY
800	1626 3608 01	PLATE	1
810	1604 9421 00	CONTROLLER	1
816	1089 0577 12	TERMINAL	19
818	1089 0310 29	RESISTOR	1
830	1089 9381 23	METER AMPERE	3
832	1089 9383 01	VOLTMETER	1
834	1089 9082 22	VOLTAGE SWITCH	1
840	1089 9423 01	CIRCUIT BREAKER	1
842	1089 0263 27	SELECTOR SWITCH	1
850	1089 9371 21	POTMETER	1
852	1089 9371 50	SPINDLE LOCK	2
854	1079 9909 20	LABEL	1
860	1089 9354 01	PANELLIGHT	1
862	1089 0374 01	LAMP	1
870	0698 5140 71	CABLE GLAND	1
872	0697 9810 58	PLUG	1
874	0697 9809 20	LOCK NUT	1
880	0698 5140 73	CABLE GLAND	1
882	0697 9810 61	PLUG	1
884	0697 9809 22	LOCK NUT	1
890	1088 0029 45	MALE INSERT	1
892	1088 0029 57	MALE CONTACT	2
894	1088 0029 61	MALE CONTACT	4
896	1088 0029 56	MALE CONTACT	2

CONTROL PANEL - QC4002 PACK - 400V - OPTIONS

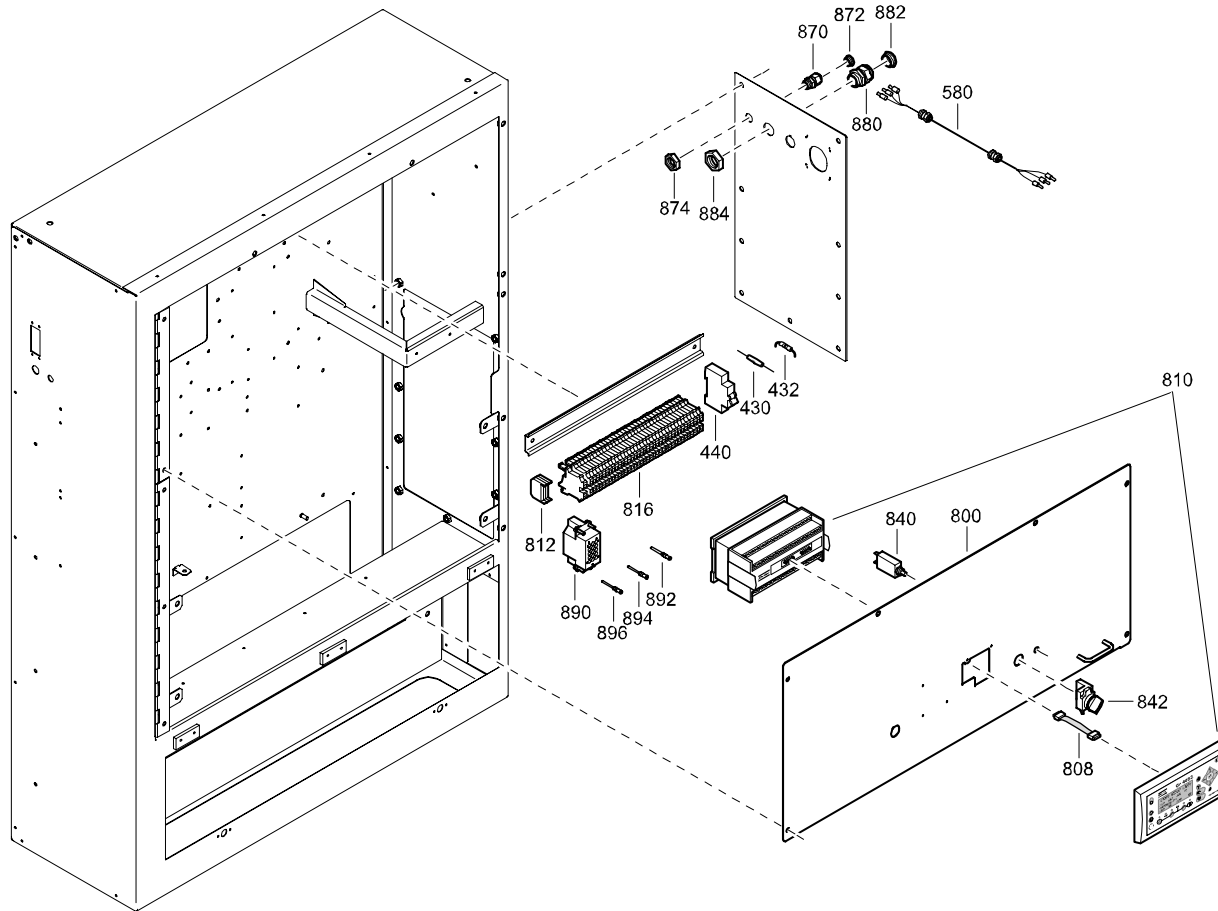

REF	PART NUMBER	DESIGNATION	QTY
430	1089 0310 29	RESISTOR	2
432	1089 0310 36	RESISTOR	1
440	1089 9410 22	AUXILIARY RELAY	3
580	1604 4640 00	WIRE HARNESS	1
800	1626 2829 01	PANEL	1
808	1089 9561 40	DISPLAY CABLE	1
810	1604 9663 00	CONTROLLER	1
812	1089 0506 19	DIODE	3
816	1089 0577 12	TERMINAL	37
840	1089 9423 01	CIRCUIT BREAKER	1
842	1089 0263 27	SELECTOR SWITCH	1
870	0698 5140 71	CABLE GLAND	1
872	0697 9810 58	PLUG	1
874	0697 9809 20	LOCK NUT	1
880	0698 5140 73	CABLE GLAND	1
882	0697 9810 61	PLUG	1
884	0697 9809 62	NUT	1
890	1088 0029 45	MALE INSERT	1
892	1088 0029 57	MALE CONTACT	2
894	1088 0029 61	MALE CONTACT	3
896	1088 0029 56	MALE CONTACT	3

